

DH-10 Heads & Controls Boom Mount or Bench Models

For use with: DH-10 Control - Boom Mount Code 10357
 DH-10 Drive - Boom Mount Codes 10358 (Std.), 10359 (Hi/Std.)
 DH-10 Boom Package Codes 10380, 10495, 10496 (Std.), and 10517, 10518, 10519 (Hi/Std.)
 Standard - Single Head Drive Codes 10190, 10191
 DH-10 Feeder Double Head - Bench Model Codes 10360 (Std.), 10361 (Hi/Std.)

Safety Depends on You

Lincoln arc welding and cutting equipment is designed and built with safety in mind. However, your overall safety can be increased by proper installation ... and thoughtful operation on your part. **DO NOT INSTALL, OPERATE OR REPAIR THIS EQUIPMENT WITHOUT READING THIS MANUAL AND THE SAFETY PRECAUTIONS CONTAINED THROUGHOUT.** And, most importantly, think before you act and be careful.

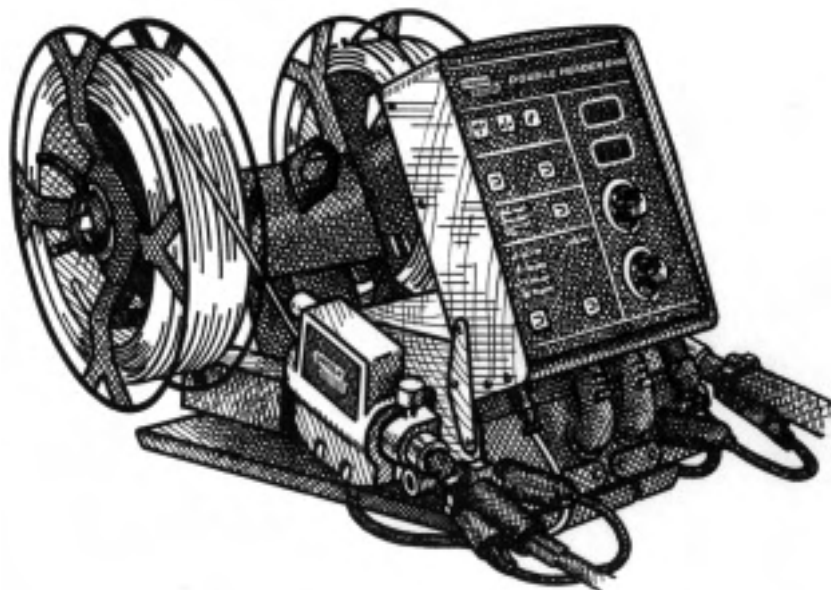

OPERATOR'S MANUAL

LINCOLN[®]
ELECTRIC

World's Leader in Welding and Cutting Products

Premier Manufacturer of Industrial Motors

• Sales and Service through Subsidiaries and Distributors Worldwide •

Cleveland, Ohio 44117-1199 U.S.A. TEL: 216.481.8100 FAX: 216.486.1751 WEB SITE: www.lincolnelectric.com

WARNING

CALIFORNIA PROPOSITION 65 WARNINGS

Diesel engine exhaust and some of its constituents are known to the State of California to cause cancer, birth defects, and other reproductive harm.

The Above For Diesel Engines

The engine exhaust from this product contains chemicals known to the State of California to cause cancer, birth defects, or other reproductive harm.

The Above For Gasoline Engines

ARC WELDING CAN BE HAZARDOUS. PROTECT YOURSELF AND OTHERS FROM POSSIBLE SERIOUS INJURY OR DEATH. KEEP CHILDREN AWAY. PACEMAKER WEARERS SHOULD CONSULT WITH THEIR DOCTOR BEFORE OPERATING.

Read and understand the following safety highlights. For additional safety information, it is strongly recommended that you purchase a copy of "Safety in Welding & Cutting - ANSI Standard Z49.1" from the American Welding Society, P.O. Box 351040, Miami, Florida 33135 or CSA Standard W117.2-1974. A Free copy of "Arc Welding Safety" booklet E205 is available from the Lincoln Electric Company, 22801 St. Clair Avenue, Cleveland, Ohio 44117-1199.

BE SURE THAT ALL INSTALLATION, OPERATION, MAINTENANCE AND REPAIR PROCEDURES ARE PERFORMED ONLY BY QUALIFIED INDIVIDUALS.



FOR ENGINE powered equipment.

1.a. Turn the engine off before troubleshooting and maintenance work unless the maintenance work requires it to be running.



1.b. Operate engines in open, well-ventilated areas or vent the engine exhaust fumes outdoors.



1.c. Do not add the fuel near an open flame welding arc or when the engine is running. Stop the engine and allow it to cool before refueling to prevent spilled fuel from vaporizing on contact with hot engine parts and igniting. Do not spill fuel when filling tank. If fuel is spilled, wipe it up and do not start engine until fumes have been eliminated.

1.d. Keep all equipment safety guards, covers and devices in position and in good repair. Keep hands, hair, clothing and tools away from V-belts, gears, fans and all other moving parts when starting, operating or repairing equipment.

1.e. In some cases it may be necessary to remove safety guards to perform required maintenance. Remove guards only when necessary and replace them when the maintenance requiring their removal is complete. Always use the greatest care when working near moving parts.



1.f. Do not put your hands near the engine fan. Do not attempt to override the governor or idler by pushing on the throttle control rods while the engine is running.

1.g. To prevent accidentally starting gasoline engines while turning the engine or welding generator during maintenance work, disconnect the spark plug wires, distributor cap or magneto wire as appropriate.



1.h. To avoid scalding, do not remove the radiator pressure cap when the engine is hot.



ELECTRIC AND MAGNETIC FIELDS may be dangerous

2.a. Electric current flowing through any conductor causes localized Electric and Magnetic Fields (EMF). Welding current creates EMF fields around welding cables and welding machines

2.b. EMF fields may interfere with some pacemakers, and welders having a pacemaker should consult their physician before welding.

2.c. Exposure to EMF fields in welding may have other health effects which are now not known.

2.d. All welders should use the following procedures in order to minimize exposure to EMF fields from the welding circuit:

2.d.1. Route the electrode and work cables together - Secure them with tape when possible.

2.d.2. Never coil the electrode lead around your body.

2.d.3. Do not place your body between the electrode and work cables. If the electrode cable is on your right side, the work cable should also be on your right side.

2.d.4. Connect the work cable to the workpiece as close as possible to the area being welded.

2.d.5. Do not work next to welding power source.

Mar '95



ELECTRIC SHOCK can kill.

3.a. The electrode and work (or ground) circuits are electrically "hot" when the welder is on. Do not touch these "hot" parts with your bare skin or wet clothing. Wear dry, hole-free gloves to insulate hands.

- 3.b. Insulate yourself from work and ground using dry insulation. Make certain the insulation is large enough to cover your full area of physical contact with work and ground.

In addition to the normal safety precautions, if welding must be performed under electrically hazardous conditions (in damp locations or while wearing wet clothing; on metal structures such as floors, gratings or scaffolds; when in cramped positions such as sitting, kneeling or lying, if there is a high risk of unavoidable or accidental contact with the workpiece or ground) use the following equipment:

- Semiautomatic DC Constant Voltage (Wire) Welder.
- DC Manual (Stick) Welder.
- AC Welder with Reduced Voltage Control.

- 3.c. In semiautomatic or automatic wire welding, the electrode, electrode reel, welding head, nozzle or semiautomatic welding gun are also electrically "hot".
- 3.d. Always be sure the work cable makes a good electrical connection with the metal being welded. The connection should be as close as possible to the area being welded.
- 3.e. Ground the work or metal to be welded to a good electrical (earth) ground.
- 3.f. Maintain the electrode holder, work clamp, welding cable and welding machine in good, safe operating condition. Replace damaged insulation.
- 3.g. Never dip the electrode in water for cooling.
- 3.h. Never simultaneously touch electrically "hot" parts of electrode holders connected to two welders because voltage between the two can be the total of the open circuit voltage of both welders.
- 3.i. When working above floor level, use a safety belt to protect yourself from a fall should you get a shock.
- 3.j. Also see Items 6.c. and 8.



ARC RAYS can burn.

4.a. Use a shield with the proper filter and cover plates to protect your eyes from sparks and the rays of the arc when welding or observing open arc welding. Headshield and filter lens should conform to ANSI Z87.1 standards.

- 4.b. Use suitable clothing made from durable flame-resistant material to protect your skin and that of your helpers from the arc rays.
- 4.c. Protect other nearby personnel with suitable, non-flammable screening and/or warn them not to watch the arc nor expose themselves to the arc rays or to hot spatter or metal.



FUMES AND GASES can be dangerous.

5.a. Welding may produce fumes and gases hazardous to health. Avoid breathing these fumes and gases. When welding, keep your head out of the fume. Use enough ventilation and/or exhaust at the arc to keep

fumes and gases away from the breathing zone. **When welding with electrodes which require special ventilation such as stainless or hard facing (see instructions on container or MSDS) or on lead or cadmium plated steel and other metals or coatings which produce highly toxic fumes, keep exposure as low as possible and below Threshold Limit Values (TLV) using local exhaust or mechanical ventilation. In confined spaces or in some circumstances, outdoors, a respirator may be required. Additional precautions are also required when welding on galvanized steel.**

- 5.b. Do not weld in locations near chlorinated hydrocarbon vapors coming from degreasing, cleaning or spraying operations. The heat and rays of the arc can react with solvent vapors to form phosgene, a highly toxic gas, and other irritating products.
- 5.c. Shielding gases used for arc welding can displace air and cause injury or death. Always use enough ventilation, especially in confined areas, to insure breathing air is safe.
- 5.d. Read and understand the manufacturer's instructions for this equipment and the consumables to be used, including the material safety data sheet (MSDS) and follow your employer's safety practices. MSDS forms are available from your welding distributor or from the manufacturer.
- 5.e. Also see item 1.b.

Mar '95

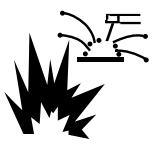

WELDING SPARKS can cause fire or explosion.

6.a. Remove fire hazards from the welding area. If this is not possible, cover them to prevent the welding sparks from starting a fire.

Remember that welding sparks and hot materials from welding can easily go through small cracks and openings to adjacent areas. Avoid welding near hydraulic lines. Have a fire extinguisher readily available.

- 6.b. Where compressed gases are to be used at the job site, special precautions should be used to prevent hazardous situations. Refer to "Safety in Welding and Cutting" (ANSI Standard Z49.1) and the operating information for the equipment being used.
- 6.c. When not welding, make certain no part of the electrode circuit is touching the work or ground. Accidental contact can cause overheating and create a fire hazard.
- 6.d. Do not heat, cut or weld tanks, drums or containers until the proper steps have been taken to insure that such procedures will not cause flammable or toxic vapors from substances inside. They can cause an explosion even though they have been "cleaned". For information, purchase "Recommended Safe Practices for the Preparation for Welding and Cutting of Containers and Piping That Have Held Hazardous Substances", AWS F4.1 from the American Welding Society (see address above).
- 6.e. Vent hollow castings or containers before heating, cutting or welding. They may explode.
- 6.f. Sparks and spatter are thrown from the welding arc. Wear oil free protective garments such as leather gloves, heavy shirt, cuffless trousers, high shoes and a cap over your hair. Wear ear plugs when welding out of position or in confined places. Always wear safety glasses with side shields when in a welding area.
- 6.g. Connect the work cable to the work as close to the welding area as practical. Work cables connected to the building framework or other locations away from the welding area increase the possibility of the welding current passing through lifting chains, crane cables or other alternate circuits. This can create fire hazards or overheat lifting chains or cables until they fail.
- 6.h. Also see item 1.c.

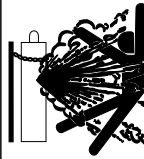

CYLINDER may explode if damaged.

7.a. Use only compressed gas cylinders containing the correct shielding gas for the process used and properly operating regulators designed for the gas and pressure used. All hoses, fittings, etc. should be suitable for the application and maintained in good condition.

- 7.b. Always keep cylinders in an upright position securely chained to an undercarriage or fixed support.
- 7.c. Cylinders should be located:
 - Away from areas where they may be struck or subjected to physical damage.
 - A safe distance from arc welding or cutting operations and any other source of heat, sparks, or flame.
- 7.d. Never allow the electrode, electrode holder or any other electrically "hot" parts to touch a cylinder.
- 7.e. Keep your head and face away from the cylinder valve outlet when opening the cylinder valve.
- 7.f. Valve protection caps should always be in place and hand tight except when the cylinder is in use or connected for use.
- 7.g. Read and follow the instructions on compressed gas cylinders, associated equipment, and CGA publication P-1, "Precautions for Safe Handling of Compressed Gases in Cylinders," available from the Compressed Gas Association 1235 Jefferson Davis Highway, Arlington, VA 22202.



FOR ELECTRICALLY powered equipment.

- 8.a. Turn off input power using the disconnect switch at the fuse box before working on the equipment.
- 8.b. Install equipment in accordance with the U.S. National Electrical Code, all local codes and the manufacturer's recommendations.
- 8.c. Ground the equipment in accordance with the U.S. National Electrical Code and the manufacturer's recommendations.

Mar '95

PRÉCAUTIONS DE SÛRETÉ

Pour votre propre protection lire et observer toutes les instructions et les précautions de sûreté spécifiques qui paraissent dans ce manuel aussi bien que les précautions de sûreté générales suivantes:

Sûreté Pour Soudage A L'Arc

1. Protégez-vous contre la secousse électrique:
 - a. Les circuits à l'électrode et à la pièce sont sous tension quand la machine à souder est en marche. Eviter toujours tout contact entre les parties sous tension et la peau nue ou les vêtements mouillés. Porter des gants secs et sans trous pour isoler les mains.
 - b. Faire très attention de bien s'isoler de la masse quand on soude dans des endroits humides, ou sur un plancher métallique ou des grilles métalliques, principalement dans les positions assis ou couché pour lesquelles une grande partie du corps peut être en contact avec la masse.
 - c. Maintenir le porte-électrode, la pince de masse, le câble de soudage et la machine à souder en bon et sûr état de fonctionnement.
 - d. Ne jamais plonger le porte-électrode dans l'eau pour le refroidir.
 - e. Ne jamais toucher simultanément les parties sous tension des porte-électrodes connectés à deux machines à souder parce que la tension entre les deux pinces peut être le total de la tension à vide des deux machines.
 - f. Si on utilise la machine à souder comme une source de courant pour soudage semi-automatique, ces précautions pour le porte-électrode s'appliquent aussi au pistolet de soudage.
2. Dans le cas de travail au dessus du niveau du sol, se protéger contre les chutes dans le cas où on reçoit un choc. Ne jamais enrouler le câble-électrode autour de n'importe quelle partie du corps.
3. Un coup d'arc peut être plus sévère qu'un coup de soleil, donc:
 - a. Utiliser un bon masque avec un verre filtrant approprié ainsi qu'un verre blanc afin de se protéger les yeux du rayonnement de l'arc et des projections quand on soude ou quand on regarde l'arc.
 - b. Porter des vêtements convenables afin de protéger la peau de soudeur et des aides contre le rayonnement de l'arc.
 - c. Protéger l'autre personnel travaillant à proximité au soudage à l'aide d'écrans appropriés et non-inflammables.
4. Des gouttes de laitier en fusion sont émises de l'arc de soudage. Se protéger avec des vêtements de protection libres de l'huile, tels que les gants en cuir, chemise épaisse, pantalons sans revers, et chaussures montantes.
5. Toujours porter des lunettes de sécurité dans la zone de soudage. Utiliser des lunettes avec écrans latéraux dans les zones où l'on pique le laitier.
6. Eloigner les matériaux inflammables ou les recouvrir afin de prévenir tout risque d'incendie dû aux étincelles.
7. Quand on ne soude pas, poser la pince à un endroit isolé de la masse. Un court-circuit accidentel peut provoquer un échauffement et un risque d'incendie.
8. S'assurer que la masse est connectée le plus près possible de la zone de travail qu'il est pratique de le faire. Si on place la masse sur la charpente de la construction ou d'autres endroits éloignés de la zone de travail, on augmente le risque de voir passer le courant de soudage par les chaînes de levage, câbles de grue, ou autres circuits. Cela peut provoquer des risques d'incendie ou d'échauffement des chaînes et des câbles jusqu'à ce qu'ils se rompent.
9. Assurer une ventilation suffisante dans la zone de soudage. Ceci est particulièrement important pour le soudage de tôles galvanisées plombées, ou cadmiées ou tout autre métal qui produit des fumées toxiques.
10. Ne pas souder en présence de vapeurs de chlore provenant d'opérations de dégraissage, nettoyage ou pistologie. La chaleur ou les rayons de l'arc peuvent réagir avec les vapeurs du solvant pour produire du phosgène (gaz fortement toxique) ou autres produits irritants.
11. Pour obtenir de plus amples renseignements sur la sûreté, voir le code "Code for safety in welding and cutting" CSA Standard W 117.2-1974.

PRÉCAUTIONS DE SÛRETÉ POUR LES MACHINES À SOUDER À TRANSFORMATEUR ET À REDRESSEUR

1. Relier à la terre le châssis du poste conformément au code de l'électricité et aux recommandations du fabricant. Le dispositif de montage ou la pièce à souder doit être branché à une bonne mise à la terre.
2. Autant que possible, l'installation et l'entretien du poste seront effectués par un électricien qualifié.
3. Avant de faire des travaux à l'intérieur de poste, la débrancher à l'interrupteur à la boîte de fusibles.
4. Garder tous les couvercles et dispositifs de sûreté à leur place.

MASTER TABLE OF CONTENTS FOR ALL SECTIONS

Safety	Page i-iv
<hr/>	
Installation	Section A
Technical Specifications — DH-10 Complete Units or Controls & Heads	A-2
General Description	A-3
Recommended Processes and Equipment	A-3
Safety Precautions	A-4
Installation of the DH-10 Boom Mount Wire Feeder Components	A-4
Wire Drive Speed Range Selection	A-5
Wire Feed Drive Roll Kits	A-6
Procedure to Install Drive Roll and Wire Guides	A-6
Gun and Cable Assemblies with Standard Connection	A-7
Gun and Cable Assemblies with Fast-Mate Connection	A-8
DH Double Head Drives Water Connections (For Water Cooled Guns)	A-8
Electrical Installation	A-9
Optional Features Installation	A-10
<hr/>	
Operation	Section B
Safety Precautions	B-2
Duty Cycle	B-2
DH-10 Control Switch Setup	B-2
Keypad and Display Operation	B-5
Dual Procedure Remote Control (K1449-1)	B-8
Wire Reel Loading - Readi-Reel, Spools or Coils	B-8
Feeding Electrode and Brake Adjustment	B-10
Drive Roll Pressure Setting	B-10
Procedure for Setting Angle of Feedplate	B-10
Gas Guard Regulator Setting	B-10
Making a Weld	B-10
Wire Reel Changing	B-11
Loss of Voltage Sense Shutdown	B-11
Wire Feed Overload Protection	B-11
Grounding Lead Protector	B-12
Explanation of Prompting and Error Messages	B-12
<hr/>	
Accessories	Section C
General	C-2
<hr/>	
Maintenance	Section D
Safety Precautions	D-2
Routine Maintenance	D-2
Wire Reel Mounting - Readi-Reels and 10 to 30 lb (4.5 to 14 kg) Spools	D-2
Avoiding Wire Feeding Problems	D-2
Periodic Maintenance	D-3
Procedure for Removing Feedplate from Wire Feeder	D-3
<hr/>	
Theory of Operation	Section E
General Description	E-2
Input Receptacle, Control Board, and Operator Controls	E-3
Wire Feed Heads and Receptacles	E-4
<hr/>	
Troubleshooting and Repair	Section F
How to Use Troubleshooting Guide	F-2
PC Board Troubleshooting Procedures	F-3
Troubleshooting Guide	F-5
Test Procedures	F-17
Component Replacement Procedures	F-31
<hr/>	
Electrical Diagrams	Section G
<hr/>	
Parts Manual	P-288

TABLE OF CONTENTS
-INSTALLATION SECTION-

Installation Section A
Technical Specifications — DH-10 Complete Units or Controls & Heads A-2
General Description A-3
Available Models A-3
Recommended Processes and Equipment A-3
Safety Precautions A-4
Installation of the DH-10 Boom Mount Wire Feeder Components A-4
Mounting the DH Double Header Wire Drive Unit (K1497-1 or -2) A-4
Mounting Single Head Wire Drive Unit (K679-1 or -2) A-4
Mounting the DH-10 Control Box (K1496-1) A-4
Connecting Wire Drive Unit to Control Box A-5
Electrode Routing A-5
Wire Drive Speed Range Selection A-5
Control Speed Range Setting A-5
Double Header (DH) Wire Drive Ratio Selection A-5
Wire Feed Drive Roll Kits A-6
Procedure to Install Drive Roll and Wire Guides A-6
Single Drive 4-Roll Kits (KP655 and KP656) A-7
DH Drive Roll Kit Installation (KP1505 and KP1507) A-7
Gun and Cable Assemblies with Standard Connection A-7
GMAW Guns A-7
Innershield Guns A-7
Gun Cable Connection with Standard Connection A-8
Gun and Cable Assemblies with Fast-Mate Connection A-8
GMAW Guns A-8
Gun Cable Connection with Fast-Mate Connection A-8
DH Double Head Drives Water Connections (For Water Cooled Guns) A-8
DH Double Head Drives A-8
Single Head Drives (K679) A-8
GMAW Shielding Gas A-9
Electrical Installation A-9
Input Cable: DH-10 Control to Power Source A-9
Optional Features Installation A-10

Return to Master TOC

Return to Master TOC

Return to Master TOC

Return to Master TOC

TECHNICAL SPECIFICATIONS – DH-10 Complete Units or Controls & Heads

The K1499-1 or -2 DH-10 consists of a control and a double head 10 series wire drive assembly pre-mounted on a platform with two 2 in. O.D. spindle mountings. Specifications for the units follow:

CONTROLS SECTION OF COMPLETE UNITS

SPEC.#	TYPE	INPUT POWER	PHYSICAL SIZE•			Weight	TEMPERATURE RATING	
			Dimensions				Operating	Storage
			Height	Width	Depth			
K1499-1	Double Head Bench Model	40 - 42 Vac + 10% 4.0 Amps 50/60 Hz	20.50 in. (520.7 mm)	19.75 in. (501.7 mm)	31.50 in. (800.1 mm)	84.5 lbs (38.3 kg)	+40°C to -20°C	+40°C to -40°C
K1499-2	Double Head Bench Model							

• Excluding Wire Reel - More detailed dimensions and weight information can be found in Section F of this manual.

WIRE DRIVE SPECIFICATIONS FOR COMPLETE UNITS•

SPEC.#	TYPE	LOW SPEED RATIO			HIGH SPEED RATIO		
		Speed	Wire Size		Speed	Wire Size	
			Solid	Cored		Solid	Cored
K1499-1	DH-10 Double Head	35 - 500 IPM (0.89 - 12.7 m/m)	.025 - 3/32 in. (0.6 - 2.4 mm)	.030 - .120 in. (0.8 - 3.0 mm)	50 - 750 IPM (1.25 - 19.0 m/m)	.025 - 1/16 in. (0.6 - 1.6 mm)	.030 - 5/64 in. (0.8 - 2.0 mm)
K1499-2	DH-10 Left Head	35 - 500 IPM (0.89 - 12.7 m/m)	.025 - 3/32 in. (0.6 - 2.4 mm)	.030 - .120 in. (0.8 - 3.0 mm)	50 - 750 IPM (1.25 - 19.0 m/m)	.025 - 1/16 in. (0.6 - 1.6 mm)	.030 - 5/64 in. (0.8 - 2.0 mm)
	DH-10 Right Head	55 - 825 IPM (1.40 - 21.0 m/m)	.025 - 1/16 in. (0.6 - 1.6 mm)	.035 - 5/64 in. (0.9 - 2.0 mm)	80 - 1250 IPM (2.00 - 31.8 m/m)	.025 - .045 in. (0.6 - 1.2 mm)	.035 - .045 in. (0.9 - 1.2 mm)

• Excluding Wire Reel - More detailed dimensions and weight information can be found in Section F of this manual.

The various components of the DH-10 system are available separately or in kits for mounting on boom assemblies. The description of the various components follow:

CONTROLS (BOOM MOUNT)

SPEC.#	TYPE	INPUT POWER	PHYSICAL SIZE•			Weight	TEMPERATURE RATING	
			Dimensions				Operating	Storage
			Height	Width	Depth			
K1496-1Δ	DH-10 Controls	40 - 42 Vac + 10% 4.0 Amps 50/60 Hz	14.80 in. (375.9 mm)	14.20 in. (360.7 mm)	4.20 in. (106.7 mm)	18.0 lbs (8.2 kg)	+40°C to -20°C	+40°C to -40°C

• Excluding Wire Reel - More detailed dimensions and weight information can be found in Section F of this manual.

Δ Included with all K1521-[] DH-10 Standard and Zipline Boom Packages

The K1496-1 DH-10 control can be used with any of the following Wire Drive Heads

WIRE DRIVE HEADS (BOOM MOUNT)•

SPEC.#	TYPE	LOW SPEED RATIO			HIGH SPEED RATIO		
		Speed	Wire Size		Speed	Wire Size	
			Solid	Cored		Solid	Cored
K1497-1▣	DH-10 Double Head	35 - 500 IPM (0.89 - 12.7 m/m)	.025 - 3/32 in. (0.6 - 2.4 mm)	.030 - .120 in. (0.8 - 3.0 mm)	50 - 750 IPM (1.25 - 19.0 m/m)	.025 - 1/16 in. (0.6 - 1.6 mm)	.030 - 5/64 in. (0.8 - 2.0 mm)
K1497-2◇	DH-10 Left Head	35 - 500 IPM (0.89 - 12.7 m/m)	.025 - 3/32 in. (0.6 - 2.4 mm)	.030 - .120 in. (0.8 - 3.0 mm)	50 - 750 IPM (1.25 - 19.0 m/m)	.025 - 1/16 in. (0.6 - 1.6 mm)	.030 - 5/64 in. (0.8 - 2.0 mm)
	DH-10 Right Head	55 - 825 IPM (1.40 - 21.0 m/m)	.025 - 1/16 in. (0.6 - 1.6 mm)	.035 - 5/64 in. (0.9 - 2.0 mm)	80 - 1250 IPM (2.00 - 31.8 m/m)	.025 - .045 in. (0.6 - 1.2 mm)	.035 - .045 in. (0.9 - 1.2 mm)
K1563-1	LN-10 Single Head	35 - 500 IPM (0.89 - 12.7 m/m)	.025 - 3/32 in. (0.6 - 2.4 mm)	.030 - .120 in. (0.8 - 3.0 mm)	50 - 750 IPM (1.25 - 19.0 m/m)	.025 - 1/16 in. (0.6 - 1.6 mm)	.030 - 5/64 in. (0.8 - 2.0 mm)
K1563-2	LN-10 Single Head	55 - 825 IPM (1.40 - 21.0 m/m)	.025 - 1/16 in. (0.6 - 1.6 mm)	.035 - 5/64 in. (0.9 - 2.0 mm)	80 - 1250 IPM (2.00 - 31.8 m/m)	.025 - .045 in. (0.6 - 1.2 mm)	.035 - .045 in. (0.9 - 1.2 mm)
K679-1*	Synergic 7F Std Drive Single Head*	50 - 770 IPM (1.27 - 19.5 m/m)	.025 - 1/16 in. (0.6 - 1.6 mm)	.035 - 5/64 in. (0.9 - 2.0 mm)	---	---	---
K679-2*	Synergic 7F Hi.-Sp. Drive Single Head*	---	---	---	80 - 1200 IPM (2.00 - 30.5 m/m)	.025 - .045 in. (0.6 - 1.2 mm)	.035 - .045 in. (0.9 - 1.2 mm)

• Excluding Wire Reel - More detailed dimensions and weight information can be found in Section F of this manual.

▣ Included in K1521-1,-2,-3 DH-10 Boom Packages.

◇ Included in K1521-4,-5,-6 DH-10 Boom Packages.

*Single head drives use 4-roll drives with 2 driven rolls (Drive roll kits not common with -10 Series drives)



Return to Section TOC

Return to Master TOC

Return to Section TOC

Return to Master TOC

Return to Section TOC

Return to Master TOC

Return to Section TOC

Return to Master TOC

GENERAL DESCRIPTION

The DH-10 is a modular line of 42 VAC input dual head 4-roll wire feeders. A single control with dual procedure presettability of wire feed speed (in IPM or M/min) and arc voltage for each head is used with a single DC welding power source.

The DH-10 models have controls providing keypad or remote selectability of wire drive head, and either of two procedures preset independently for each head.

The units offer 4 independently selectable gun trigger modes for each head procedure; cold feed, 2 step and 4-step trigger and spot weld mode.

Also, 4 selectable, presettable timers for each head procedure; preflow, postflow, burnback and spot weld time.

Arc starting can be optimized for each head procedure with 5 selectable wire feed acceleration rates, and independent control of slower run-in procedure.

A gas purge key is provided, as well as cold feed forward and reverse keys with independently adjustable forward feed speed setting.

All of these features are selected with a tactile-feel keypad, and are set independently for each head using one of two rotating knob encoders, setting levels are displayed on one of two digital LED displays.

The DH Wire Drive assemblies include two heavy duty heads with externally changeable gear ratio and 4 driven roll drives housed together in a single combination mounting and connection box. Gun adapters are available to permit use with a variety of standard welding guns.

AVAILABLE MODELS

The DH-10 Wire Feeder system is available configured in both Bench and Boom models.

Bench Models consists of a DH-10 control and a DH double header wire drive assembly premounted on a platform with a dual 2 in. O.D. spindle mounting.

Boom Models consist of a DH-10 control and a choice of wire drives designed to be mounted separately and joined by available head to control cable assemblies.

The head to control cable assemblies are available in two types; one control cable is required for each head:

K1498-"L" Includes a control cable with a 14-pin ms style connection on each end, and

a 3/0 weld cable. Available in lengths "L" of 16, 20, or 25 ft (4.9, 6.1, or 7.6 m) for recommended boom lengths of 8-9 ft, 10-12 ft, or 16-18 ft (2.4-2.7 m, 3.0-3.7 m, or 4.9-5.5 m) respectively.

K681-"L" Same as above but does not include weld cable available in lengths "L" of 12, 16, or 25 ft (3.6, 4.9, or 7.6 m).

The DH-10 boom packages are available in standard packages as follows:

K1521-1 includes:

- DH-10 Control (Same as K1496-1)
- DH-10 Std. Wire Drive Head (Same as K1497-1)
- 16 ft (4.9 m) Control Cable (Same as K681-16)
- 16 ft (4.9 m) Control and Weld Cable (Same as K1498-16)

K1521-2 includes:

- DH-10 Control (Same as K1496-1)
- DH-10 Std. (Left)/Hi-Speed (Right) Heads (Same as K1497-2)
- 16 ft (4.9 m) Control Cable (Same as K681-16)
- 16 ft (4.9 m) Control and Weld Cable (Same as K1498-16)

Also there are four additional Zipline Boom Packages (K1521-2, -3, -5, and -6). For specifications see IM596-4.

RECOMMENDED PROCESSES AND EQUIPMENT

The DH-10 Wire Feeder system is recommended for use with solid wire gas-metal-arc or CV Submerged arc processes, as well as cored wire for Outershield GMA or Innershield processes.

The wire type and size range for the wire drive used, and gear ratio change selected, are given in the Specifications.

Recommended power sources are Lincoln Electric Company constant voltage power sources with 42 VAC auxiliary power and a 14-pin connector receptacle. At the time of printing these include: CV 250, CV300-I, CV-300, CV400-I, CV-400, CV500-I, DC-400, CV-655, Invertec V300-PRO, DC-650 PRO and DC-655.

The DC-250, DC-600, DC-1000 and the Pulse Power 500 (Non-Pulsed CV mode only) may also be used with the DH-10 if the optional K1520-1 115V / 42V Transformer Kit is used.

SAFETY PRECAUTIONS

⚠ WARNING



ELECTRIC SHOCK can kill.

- Turn the input power off at the power source disconnect switch before attempting to connect the input power to the DH-10 Control.
- Only qualified personnel should perform this installation.

INSTALLATION OF THE DH-10 BOOM MOUNT WIRE FEEDER COMPONENTS

Mounting the DH Double Header Wire Drive Unit (K1497-1 or -2)

Mount the DH wire drive unit to the boom or structure using the four 5/16-18 threaded mounting holes located on the bottom of the DH drive connection box. See Figure A.1 for the size and location of the mounting holes. The feed plate assembly is electrically "hot" when the gun trigger is pressed. Therefore, make certain the feed plate does not come in contact with the structure on which the unit is mounted.

The wire drive unit should be mounted so that the drive rolls are in a vertical plane so dirt will not collect in the drive roll area. Pivot the feed plate so it will point down at an angle so the wire feed gun cable will not be bent sharply as it comes from the unit. See *Procedure for setting angle of Feed Plate* in the *Operation* section of this manual.

FIGURE A.1

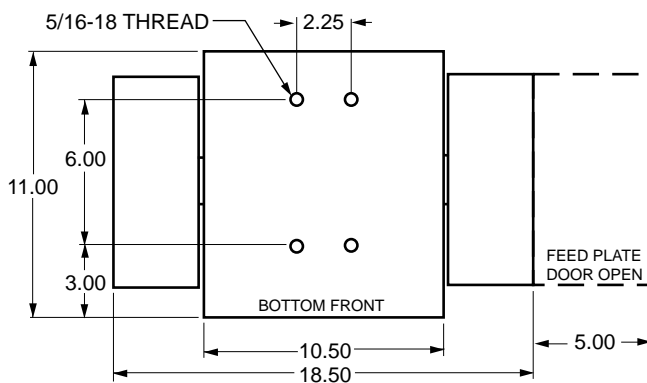

Mounting Single Head Wire Drive Unit (K679-1 or -2)

Mount the wire feed unit by means of the insulated mounting bracket attached to the bottom of the gearbox. Reference L9777 (included with Drive unit) to find the size and location of the mounting holes. The gearbox assembly is electrically "hot" when the gun trigger is pressed. Therefore, make certain the gearbox does not come in contact with the structure on which the unit is mounted.

The wire feed unit should be mounted so that the drive rolls are in a vertical plane so dirt will not collect in the drive roll area. Position the mechanism so it will point down at about a 45° angle so the wire feed gun cable will not be bent sharply as it comes from the unit.

Mounting the DH-10 Control Box (K1496-1)

The same control box is used for both a DH double header drive, or up to two single head drives. The back plate of the control box has two keyhole slots and one bottom slot for mounting. See Figure A.2 for the size and location of these slots. Mount the box at some convenient location close to the wire drive unit which will enable the desired control cable to reach between the control box and the wire drive unit.

1. Drill the required holes in the mounting surface, partially install 1/4-20 screws.
2. Mount the box.
3. Tighten the screws.

FIGURE A.2

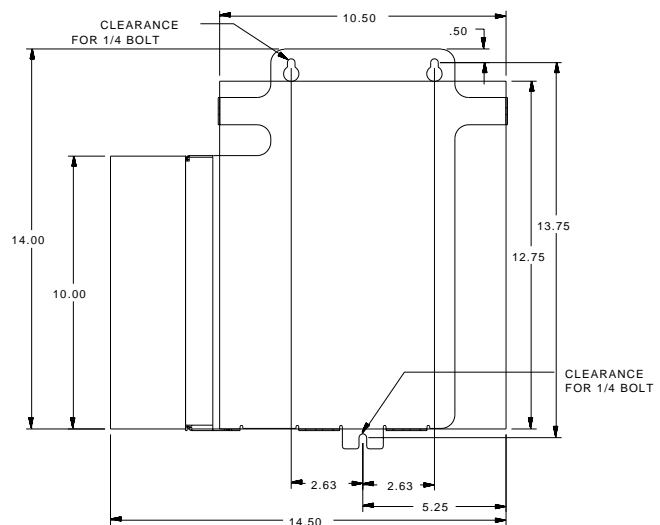

Connecting Wire Drive Unit to Control Box

One head to control cable assembly is required for each head being used; however, only one electrode cable is required if an electrode cable jumper (provided) is connected between the two heads. The Head to Control cable assemblies are available in two types:

K1498-“L” - Includes a control cable with 14-pin ms-style connectors on each end, and a 3/0 weld cable (rated 600 amps, 60% duty cycle) to route between the wire drive and the control box. Available in lengths “L” of 16 ft (4.9 m) and 25 ft (7.6 m).

K681-“L” - Same as K1498, but does not include weld cable. Available in lengths “L” of 12 ft (3.6 m), 16 ft (4.9 m) and 25 ft (7.6 m).

1. Making certain the cables are protected from any sharp corners which may damage their jackets, mount the cable assembly along the boom so the end with the female amphenol connector pins is at the wire feed unit.
2. Connect the 14-socket cable connectors to the mating receptacles on the back of the wire feed unit connection box. Feeder Head 1 uses the left receptacle and Feeder Head 2 uses the right receptacle, when facing the front of the wire drive.
3. At the same end, connect the electrode lead to the 1/2 in. connection bolt on the rear of the left wire drive head feed plate. If only one electrode cable is being used, comparable size electrode cable jumper (provided) must be connected between the two heads.
4. At the control box end, connect the 14-pin connectors of the cables to the mating receptacles on the bottom of the control box. Feeder Head 1 should be connected to the left receptacle and Feeder Head 2 should be connected to the right receptacle, when facing the front of the control box.
5. At the control box current sensor, slip the cover box up off the sensor and connect the electrode cable(s) to the top bolt connection.

Electrode Routing

The electrode supply may be either from reels, Readi-Reels, spools, or bulk packaged drums or reels. Observe the following precautions:

1. The electrode must be routed to the wire drive unit so that the bends in the wire are at a mini-

mum, and also that the force required to pull the wire from the reel into the wire drive unit is kept at a minimum.

2. The electrode is “hot” when the gun trigger is pressed and must be insulated from the boom and structure.
3. If more than one wire feed unit shares the same boom and are not sharing the same power source output stud, their wire and reels must be insulated from each other as well as insulated from their mounting structure.

WIRE DRIVE SPEED RANGE SELECTION

The rated speed and wire size range for each wire drive head is shown in **Specifications** in the front of this section.

Control Speed Range Setting

The speed range is set up to match each wire feed head connected to the DH-10 control by properly setting the switch (S2) code on the control board inside the control box. See **Operation, Setting the DIP Switches** for setting instructions.

Double Header (DH) Wire Drive Ratio Selection

The Double Head type drives include two external gear sizes; a 1 in. diameter gear and a 1-1/2 in. diameter gear. The smaller gear provides the low speed range ratio, and the larger gear provides the high speed range ratio per **Specifications** in the front of this section.

The following procedure is for changing ratio of the DH drive:

1. Pull open the Pressure Door.
2. Remove the Phillips head screw retaining the pinion gear to be changed and remove the gear. If the gear is not easily accessible or difficult to remove, remove the feedplate from the gear box.

To remove feedplate:

- a. Loosen the clamping collar screw using a 3/16 in. Allen wrench. The clamping collar screw is accessed from the bottom of the feedplate. It is the screw which is perpendicular to the feeding direction.
- b. Loosen the retaining screw, which is also accessed from bottom of feeder, using a 3/16 in. Allen wrench. Continue to loosen the screw until the feedplate can be easily pulled off of the wire feeder.
3. Loosen, but do not remove, the screw on the lower right face of the feedplate with a 3/16 in. Allen wrench.
4. Remove the screw on the left face of the feedplate. If changing from high speed (larger gear) to low speed (smaller gear), line the lower hole on the left face of the feedplate with the threads on the clamping collar. Line the upper hole with the threads to install larger gear for high speed feeder. If feedplate does not rotate to allow holes to line up, further loosen the screw on right face of feedplate.
5. Install gear onto output shaft and secure with flat washer, lock washer, and Phillips head screw which were previously removed.
6. Tighten the screw on lower right face of feedplate.
7. Install gear onto output shaft and secure with flat washer, lock washer, and Phillips head screw which were previously removed.
8. Re-attach feedplate to wire feeder if removed in Step 2.
9. Feedplate will be rotated out-of-position due to the gear change. To re-adjust angle of feedplate:
 - a. Loosen the clamping collar using a 3/16 in. Allen wrench. The clamping collar screw is accessed from the bottom of the feedplate. It is the screw which is perpendicular to the feeding direction.
 - b. Rotate feedplate to the desired angle and tighten clamping collar screw.
10. Make sure to properly set the switch (S2) code on the control board inside the control box for the new gear size installed. See **Operation, Setting the DIP Switches** for setting instructions.

WIRE FEED DRIVE ROLL KITS

NOTE: The maximum rated solid and cored wire sizes for each wire drive head and selected drive ratio is shown on the **Specifications** in the front of this section.

The electrode sizes that can be fed with each roll and guide tube are stenciled on each part. Check the kit for proper components.

Single Head Drives (K679) use 4-Roll drive roll kits with 2 driven rolls, per **Table C.1** in **Accessories**. These kits are common with those used for the 4-Roll LN-7 GMA and LN-9 GMA Lincoln Wire Feeders, but are not common with those used with the DH wire drive units. Installation instructions are included with the kits.

DH Double Head Drives use 4-Roll drive roll kits with 4 driven rolls, per **Table C1** in **Accessories**. Each head requires a separate drive roll kit.

PROCEDURE TO INSTALL DRIVE ROLL AND WIRE GUIDES

⚠ WARNING



ELECTRIC SHOCK can kill.

- Do not touch electrically live parts such as output terminals or internal wiring.
- When inching with gun trigger, electrode and drive mechanism are “hot” to work and ground and could remain energized several seconds after the gun trigger is released.
- Turn OFF input power at welding power source before installation or changing drive roll and/or guide tubes.
- Welding power source must be connected to system ground per the National Electrical Code or any applicable local codes.
- Only qualified personnel should perform this installation.

Observe all additional Safety Guidelines detailed throughout this manual.

Single Drive 4-Roll Kits (KP655 and KP656)

1. Turn OFF welding power source.
2. Release both quick release levers by sliding the levers sideways into the open positions.
3. Remove clamping screw & clamping collar from the drive shaft closest to the incoming side of the feeder.
4. Install drive roll onto keyed shaft. (Do not exceed the maximum wire size rating of the wire drive.) Replace collar and tighten clamping screw.
5. Back out the set screw for the middle guide tube. Install the middle guide tube and slide it up against the drive roll. DO NOT TIGHTEN THE MIDDLE GUIDE AT THIS TIME.
6. Install the outgoing drive roll following the same procedure as steps 3 & 4.
7. Center the middle guide between the two drive rolls and tighten in place.
8. Back out the screws for the incoming and outgoing guide tubes.
9. Install the longer guide tube in the rear hole near the incoming drive roll. Slide the tube in until it almost touches the roll. Tighten in place.
10. Install the remaining guide tube in the front hole. Be certain that the proper plastic insert is used. Fine wire chisel point tube must have largest radius next to drive roll. Tighten in place.
11. Re-latch both quick release levers.
12. To start new electrode, straighten the first 6 in. (150 mm) and cut off the first 1 in. (25 mm). Insert free end through the incoming tube. Press gun trigger and push wire into the drive roll.

To set idle pressure, see *Idle Roll Pressure Setting* in *Operation*.

DH Drive Roll Kit Installation (KP1505 and KP1507)

1. Turn OFF Welding Power Source.
2. Pull open Pressure Door to expose rolls and wire guides.
3. Remove Outer Wire Guide by turning knurled thumb screws to unscrew from Feedplate.
4. Remove drive rolls, if any are installed, by pulling straight off shaft. Remove inner guide.

5. Insert inner Wire Guide, groove side out, over the two locating pins in the feedplate.
6. Install each drive roll by pushing over shaft until it butts up against locating shoulder on the drive roll shaft. (Do Not exceed maximum wire size rating of the wire drive).
7. Install Outer Wire Guide by sliding over locating pins and tightening in place.
8. Engage upper drive rolls if they are in the "open" position and close Pressure Door.

To set idle roll pressure, see *Idle Roll Pressure Setting* in *Operation*.

GUN AND CABLE ASSEMBLIES WITH STANDARD CONNECTION

The DH Wire Drive Heads each require a K1500 Gun Adapter installed See *Gun Adapters* in *Accessories* section.

GMAW Guns

An expanding line of Magnum gun and cable assemblies are available to allow welding with solid and cored electrodes using the GMAW process. See the appropriate Magnum literature for descriptions of the 200 to 550 ampere air cooled gun and cables that are available. Gun cable lengths range from 10 ft (3.0 m) to 25 ft (7.6 m) and feed electrode sizes 0.025 in. (0.6 mm) to 3/32 in. (2.4 mm). The entire line of Magnum Fast-Mate gun and cable assemblies can also be used by installing a K489-2 Fast-Mate adapter kit. See *Gun and Cable Assemblies with Fast-Mate Connection* in this section for details.

Innershield Guns

K126 and K115 gun and cable assemblies are available to allow welding with Innershield electrodes. Gun cable lengths range from 10 ft (3.0 m) to 15 ft (4.5 m) The 350 ampere K126 will feed electrode sizes 0.062 in. (1.6 mm) to 3/32 in. (2.4 mm). The 450 ampere K115 will feed 5/64 in. (2.0 mm) to 3/32 in. (2.4 mm) electrode.

Three smoke extraction gun and cable assemblies are available, 250 ampere K309, 350 ampere K206 and the 500 ampere K289. All gun cable lengths are 15 ft (4.5 m). These guns will feed electrode sizes 0.062 in. (1.6 mm) to 3/32 in. (2.4 mm) and require the use of the K184 vacuum unit for use with the DH-10.

Gun Cable Connection with Standard Connection

1. Check that the drive rolls and guide tubes are proper for the electrode size and type being used. If necessary, change them per **Wire Drive Roll Kits** in this section.
2. Lay the cable out straight. Insert the connector on the welding conductor cable into the brass conductor block on the front of the wire drive head. Make sure it is all the way in and tighten the hand clamp. Keep this connection clean and bright. Connect the trigger control cable polarized plug into the mating 5 cavity receptacle on the front of the wire drive unit.
3. For GMA Gun Cables with separate gas fitting (DH Drive using K1500-1 Gun Adapter), connect the 3/16 in. I.D. gas hose from the wire drive unit to the gun cable barbed fitting.

GUN AND CABLE ASSEMBLIES WITH FAST-MATE CONNECTION

(Requires K489-2 Fast Mate™ Adapter Kit used with the DH K1500-1 Gun Adapter)

GMAW Guns

An expanding line of Magnum Fast-Mate™ air cooled and water cooled gun and cable assemblies are available to allow welding with solid and cored electrodes using the GMAW process. See the appropriate Magnum literature for descriptions of the 200 to 400 ampere air cooled gun and cables that are available as well as the Magnum “Super Cool” 450 ampere water cooled gun and cable. Gun cable lengths range from 10 ft (3.0 m) to 25 ft (7.6 m) and feed electrode sizes 0.025 in. (0.6 mm) to 5/64 in. (20 mm).

An expanding line of Magnum X-Tractor gun and cable assemblies provides fume extraction capability for welding with solid and cored electrodes using the GMAW process. See the appropriate Magnum literature for descriptions of the 250 to 400 ampere air cooled gun and cables that are available. Gun cable lengths range from 10 ft (3.0 m) to 15 ft (4.5 m) and feed electrode sizes 0.035 in. (0.9 mm) to 1/16 in. (1.6 mm). These guns require the use of either the K173-1 or K184* vacuum units.

*Requires S14927-8 connector hose and an S20591 hose adapter.

Gun Cable Connection with Fast-Mate Connection

1. Check that the drive rolls, feeder guide tubes and gun connector guide tube are appropriate for the electrode size being used. If necessary, change them per **Wire Drive Roll Kits** in this section.
2. Connect gun to gun connector making sure all pins and gas tube line up with appropriate holes in connector. Tighten gun by turning large nut on gun cable clockwise.

DH DOUBLE HEAD DRIVES WATER CONNECTIONS (FOR WATER COOLED GUNS)

DH Double Head Drives: must have a K590-4 Water Connection Kit installed for each water cooled gun. (See **Accessories**).

Using male quick-connect fittings, connect the water hoses to the coolant inlet and outlet on the back of the wire drive. Connect the other ends of these hoses to the appropriate ports on the water cooling units.

In the event the water line fittings on your water cooled gun are incompatible with the female quick-connects on the front of the wire drive, male quick-connects (L.E. Part No. S19663) are provided in the Kit for installation on 3/16 in. (5 mm) I.D. hose (Customer to provide appropriate clamps). The feeder connectors self seal when disconnected.

Single Head Drives (K679): Must have a K682-2 Water Connection Kit installed. (See **Accessories**).

Using hose clamps provided with the K682-2 kit, connect appropriate water hoses to the coolant inlet and outlet fittings on the back of the K682-2 Kit. Connect the other ends of these hoses to the appropriate ports on the water cooling units.

In the event the water line fittings on your water cooled gun are incompatible with the female quick-connects on the front of the K682-2 Kit male quick-connects are provided with the kit for installation on 3/16 in. (5 mm) I.D. hose (Customer to provide appropriate clamps). The feeder connectors self seal when disconnected.

GMAW Shielding Gas

⚠ WARNING

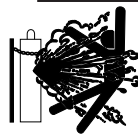

CYLINDER may explode if damaged.

- Keep cylinder upright and chained to support.
- Keep cylinder away from areas where it may be damaged.
- Never lift welder with cylinder attached.
- Never allow welding electrode to touch cylinder.
- Keep cylinder away from welding or other live electrical circuits.



BUILDUP OF SHIELDING GAS may harm health or kill.

- Shut off shielding gas supply when not in use.

SEE AMERICAN NATIONAL STANDARD Z-49.1, "SAFETY IN WELDING AND CUTTING" PUBLISHED BY THE AMERICAN WELDING SOCIETY.

The customer must provide a cylinder of shielding gas, a pressure regulator, a flow control valve, and a hose from the flow valve to the gas inlet fitting of the wire drive unit.

Connect a supply hose from the gas cylinder flow valve outlet to the 5/8-18 female inert gas fitting on the back panel of the wire drive or, if used, on the inlet of the Gas Guard regulator. (See Below).

Gas Guard Regulator - The Gas Guard Regulator is an optional accessory (K659-1) on these models.

Install the 5/8-18 male outlet of the regulator to the 5/8-18 female gas inlet on the back panel of the wire drive. Secure fitting with flow adjuster key at top. Attach gas supply to 5/8-18 female inlet of regulator per instructions above.

ELECTRICAL INSTALLATION

⚠ WARNING



ELECTRIC SHOCK can kill.

- Do not touch electrically live parts such as output terminals or internal wiring.
- When inching with gun trigger, electrode and drive mechanism are "hot" to work and ground and could remain energized several seconds after the gun trigger is released.
- Turn OFF input power at welding power source before installation or changing drive roll and/or guide tubes.
- Welding power source must be connected to system ground per the National Electrical Code or any applicable local codes.
- Only qualified personnel should perform this installation.

Observe all additional Safety Guidelines detailed throughout this manual.

Input Cable: DH-10 Control to Power Source

Available Cable Assemblies:

K1501 (Control Cable Only) Consists of a 9-conductor control cable with a 14-pin control cable plug, without electrode cable, and is available in lengths of 10 ft (3 m), 17 ft (5 m), 25 ft (7.6 m), 33 ft (10 m), 50 ft (15 m) and 100 ft (30 m).

K1502 Consists of a 9-conductor control cable with a 14-pin plug and a 3/0 (85 mm²) electrode cable with stud terminal. It is rated at 600 amps, 60% duty cycle and is available in lengths of 10 ft (3 m), 17 ft (5 m), 25 ft (7.6 m), 33 ft (10 m) and 50 ft (15 m) and 100 ft (30 m) is also available with a 4/0 (107 mm²) electrode cable.

K1503 Consists of a 9-conductor control cable with a 14-pin plug and 2/0 (67 mm²) electrode cable with Twist-Mate™ connector. It is rated at 500 amps, 60% duty cycle and is available in lengths of 10 ft (3 m), 17 ft (5 m), 25 ft (7.6 m), 33 ft (10 m) and 50 ft (15 m) and 100 ft (30 m) is also available with a 3/0 (85 mm²) electrode cable.

With input power disconnected from the power source, install the input cable per the following:

1. Connect the end of the control cable with the 14-pin cable plug to the mating receptacle on the power source.
2. Connect the electrode lead to the power source output terminal of the desired polarity.
3. Connect the 9-socket plug of the control cable to the mating receptacle on the bottom of the DH-10 control box.
4. Slip the current sensor cover off enough to expose the input connector stud. Connect the electrode cable from the power source to this stud with the nut provided, then reclose the current sensor cover.

Work Cable

Connect a work lead of sufficient size and length (per the following table) between the proper output terminal on the power source and the work. Be sure the connection to the work makes tight metal-to-metal electrical contact.

Current 60% Duty Cycle	Copper Work Cable Size, AWG
	Up to 100 ft Length (30 m)
400 Amps	00 (67 mm ²)
500 Amps	000 (85 mm ²)
600 Amps	000 (85 mm ²)

OPTIONAL FEATURES INSTALLATION

K1501, K1502 and K1503 Input Cable Assemblies

See *Electrical Installation* for instructions.

K1520-1 115V/42V Transformer Kit. Required to use DH-10 with Lincoln Power Sources without 42 VAC auxiliary and a 14-pin connector receptacle. These power sources include the DC-250, DC-600, DC-1000 and Pulse Power 500. Also can be used with older DC-400 models. Mounts on power source per installation instructions included with the kit.

Spindle Adapters

K162H Spindle for boom mounting Readi-Reels and 2 in. (51 mm) I.D. spools with 60 lb (27.2 kg) capacity. User mounted to appropriately prepared boom framework. Includes an easily adjustable friction brake for control of overrun (Two 2 in. spindles standard on DH-10 Bench models).

When a 2 in. (51 mm) spindle is used with Readi-Reels, or coils not on 12 in. (305 mm) O.D. spools, an adapter is required:

Coil Adapter

K1504-1 Permits 50 to 60 lb (22.7 to 27.2 kg) coils to be mounted on 2 in. (51 mm) O.D. spindles.

K435 Permits 14 lb (6 kg) Innershield coils to be mounted on 2 in. (51 mm) O.D. spindles.

K468 Permits 8 in. (203 mm) O.D. spools to be mounted on 2 in. (51 mm) O.D. spindles.

Readi-Reel Adapters

K363P Adapts Lincoln Readi-Reel coils of electrode 30 lb (14 kg) and 22 lb (10 kg) to a 2 in. (51 mm) spindle. Durable molded plastic one piece construction. Designed for easy loading; adapter remains on spindle for quick changeover.

K438 Adapts Lincoln Readi-Reel coils of electrode 50 to 60 lb (22.7 to 27.2 kg) to a 2 in. (51 mm) spindle.

K1634-1 Wire Reel Enclosure Kit. Provides the necessary parts to cover the wire and protect it from excessive dirt and contamination. This kit is **not** for use with 60 lb coils (most 30 lb, 15 kg, 44 lb fiber spools, and smaller coils will work). The kit includes a two-part reel cover, a Magnum conduit adapter for the incoming end of the wire feeder feed plate and a short length of

DH-10

LINCOLN[®]
ELECTRIC

Magnum conduit to go between the reel cover and the feedplate.

Gun Adapters (For DH Wire Drive Heads)

Adapts DH heads for desired gun connection

K489-7 for Fast-Mate (or European style) gun connections, including Dual Schedule Fast-Mate guns.

K1500-1 for standard Lincoln Innershield gun connection, or with Fast-Mate™ guns with K489-2 Fast-Mate Adapter Kit. Also for Magnum 200/300/400 with K466-1 Connection Kit or Magnum 550 with K613-1.

K1500-2 for Magnum 200/300/400 gun with K466-10 Connection Kit. (Also Tweco 4).

K1500-3 for Magnum 550 gun with K613-7 Connection Kit. (Also Tweco 5).

Install to either Head of the DH drive per instructions shipped with the Gun Adapter.

Dual Procedure Switch Options

K683-1 Dual Procedure Switch (One per gun) - Requires K686-2 Adapter for DH-10. Kit includes gun switch, and mountings for Lincoln Innershield and Magnum guns, with 15 ft (4.5 m) control cable and 3-pin plug. K686-2 Adapter permits 3-pin plug and 5-pin gun trigger plug to be connected to DH-10 5-pin Trigger/Dual Procedure receptacle.

Connect the 5-pin plug of the K686-2 Adapter to the DH-10 Wire Feeder Trigger/Dual Procedure 5-socket receptacle.

The 3-pin plug of the K683-1 Dual Procedure switch connects to the 3-socket receptacle of the Adapter, and the 5-pin plug of the welding gun connects to the 5-socket receptacle of the Adapter.

K683-3 Dual Procedure Switch (One per gun) Kit includes gun switch, and mountings for Lincoln Innershield and Magnum guns, with 15 ft (4.5 m) control cable and 5-pin plug with two leads to connect to gun trigger.

Connect the 5-pin plug of the K683-3 Dual procedure Switch to the DH-10 Wire Feeder Trigger/Dual Procedure 5-socket receptacle.

The two lead plug cord extending out of the 5-pin plug of the Dual Procedure switch is to be connected to the two trigger leads of the welding gun per the instructions shipped with the kit.

K590-4 Water Connection Kit (For DH Drive Only). Install per the instructions shipped with the kit. One used per gun.

K682-2 Water Connection Kit (K679 Single Head Drive Only). Install to either side of wire feed unit mounting bracket per instructions shipped with the kit.

K659-1 Gas Guard Regulator (One used per gun). Adjustable flow regulator with removable adjuster key for CO2 and Argon blend gases. Mounts onto feeder inlet, and reduces gas waste and arc start "blow" by reducing surge caused by excess pressure in supply hose.

Install the 5/8-18 male outlet of the regulator to one, or both of the 5/8-18 female gas inlets on the back panel of the wire drive. Secure fitting with flow adjuster key at top. Attach gas supply to 5/8-18 female inlet of regulator per **GMAW Shielding Gas** in this section.

K1449-1 Dual Procedure Remote Control. Provides remote rotating knob encoder control of Wire Feed Speed and Voltage, along with a dual procedure selector switch, when the remote control is connected and REMOTE is selected by the DH-10 Procedure key. The DH-10 A or B procedure light will also be on to indicate which procedure is selected by the remote control.

The 4-pin plug of the remote control connects to the mating receptacle on the bottom of the DH-10 Control box. Only one remote is used with a DH-10 control.

The K1450-"L" Extension cable is used to extend the 16 ft (5 m) cable attached to the remote control. Lengths "L" are available to match the Length of the control to boom mount wire drive cable being used.

K1558-1 Remote Switch Interface Module, can be used with the DH-10, using a G3041-2 (or higher) Control Board.

The module provides for user interface connection of an external switch (flow switch, etc) which must be closed to enable the feeder welding operation. Also, the module provides for interface connection of external equipment (fume extractor, etc.) To the module's isolated relay contacts which actuate when the feeder welding gas solenoid is activated (representing welding operation in process).

When used with the DH-10, the module provides these input and output switch function connections independently for each head operation.

This module is necessary when using the K1536-1 waterflow sense kit with the DH-10.

Return to Section TOC
Return to Master TOC

Return to Section TOC
Return to Master TOC

Return to Section TOC
Return to Master TOC

Return to Section TOC
Return to Master TOC

TABLE OF CONTENTS -OPERATION SECTION-

	Section B
Operation	B-2
Safety Precautions	B-2
Duty Cycle	B-2
DH-10 Control Switch Setup	B-2
Setup DIP Switch Access	B-2
Setting the DIP Switches	B-2
Wire Drive Head Selection	B-2
Welding Power Source Selection	B-3
Metric/English Wire Feed Speed Display Selection	B-4
4-Step Trigger Mode Operation Selection	B-4
Low Security Mode Selection	B-5
High Security Mode Selection	B-5
Keypad and Display Operation	B-5
Keypad and Display Description	B-5
Power-Down Save	B-5
Operation Keys	B-6
Trigger Mode Selection	B-6
Display Control Keys	B-7
Digital "Memory" Voltmeter	B-7
Acceleration Selection	B-7
Security Modes	B-8
Dual Procedure Remote Control (K1449-1)	B-8
Wire Reel Loading - Readi-Reels, Spools or Coils	B-8
To Mount a 30 lb (14 kg) Readi-Reel Package (Using the Molded Plastic K363-P Readi-Reel Adapter) (FIGURE B.1)	B-8
To Mount 10 to 44 lb (4.5 to 20 kg) Spools (12 in/300 mm Diameter) or 14 lb (6 kg) Innershield Coils (FIGURE B.1)	B-9
To Mount a 50 to 60 lb (22.7 to 27.2 kg) Coil: (Using K1504-1 Coil Reel)	B-9
Feeding Electrode and Brake Adjustment	B-10
Drive Roll Pressure Setting	B-10
Procedure for Setting Angle of Feedplate	B-10
Gas Guard Regulator Setting	B-10
Making a Weld	B-10
Wire Reel Changing	B-11
Loss of Voltage Sense Shutdown	B-11
Wire Feed Overload Protection	B-11
Grounding Lead Protector	B-12
Explanation of Prompting and Error Messages	B-12

SAFETY PRECAUTIONS

⚠ WARNING



ELECTRIC SHOCK can kill.

- Do not touch electrically live parts such as output terminals or internal wiring.
- Unless using cold feed feature when inching with gun trigger, electrode and drive mechanism are “hot” to work and ground and could remain energized several seconds after the gun trigger is released.
- Turn OFF input power at welding power source before Control switch setup or changing drive roll and/or guide tubes.
- Welding power source must be connected to system ground per the National Electrical Code or any applicable local codes.
- Only qualified personnel should operate this Equipment.

Observe all additional Safety Guidelines detailed throughout this manual.

DUTY CYCLE

The DH-10 models are rated at 60% duty cycle* for a maximum current of 600 amps.

* Based on a 10 minute time period (6 minutes on, and 4 minutes off).

DH-10 CONTROL SWITCH SETUP

Initial set up of the DH-10 control for the system components being used and for general operator preferences is done using a pair of 8-pole DIP switches located inside the DH-10 control box.

Setup DIP Switch Access

1. Shut off the input power to the DH-10 control by turning off the power at the welding power source it is connected to.
2. Remove the two screws on the top of the DH-10 control box door and swing the door down to open.
3. Locate the two 8-pole DIP switches, near the top left corner of the DH-10 Control P.C. board, labeled S1 and S2.
4. Switch settings are only programmed during input power-up restoration.

Setting the DIP Switches

The DIP switches are each labeled with an “ON” arrow showing the on direction for each of the 8 individual switches in each DIP switch (S1 and S2). The functions of these switches are also labeled and set as described below:

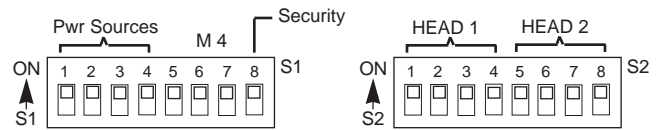

Wire Drive Head Selection

The DH-10 control is set up for proper presettable wire feed speed by setting S2 DIP switches (1 to 4) for Head 1 (left side head) and DIP switches (5 to 8) for Head 2 (right side head) as appropriate per the following examples for the head specification and DH drive external gear selection being used:

NOTE: Set the proper 4 switches labelled for Head 1 (Left Head) or Head 2 (Right Head) as appropriate for the way that Head is being used.

DH-10 HEADS:

For K1497-1 (DH-10 Boom) or K1499-1 (DH-10 Bench) with 35-500 IPM (0.89-12.7 m/m) Low Speed Ratio set S2 DIP switches as follows:

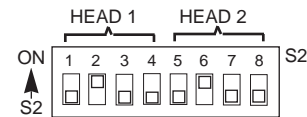

For K1497-1 (DH-10 Boom) or K1499-1 (DH-10 Bench) with 50-750 IPM (1.25-19.0 m/m) High Speed Ratio set S2 DIP switch as follows: (initial factory setting)

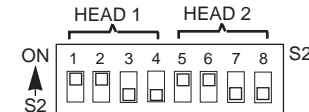

For K1497-2 (DH-10 Boom) or K1499-2 (DH-10 Bench) with Left Head 35-500 IPM (0.89-12.7 m/m) & Right Head 55-825 IPM (1.40-21.0 m/m) Low Speed Ratio set S2 DIP switch as follows:

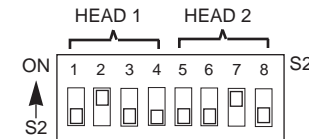

For K1497-2 (DH-10 Boom) or K1499-2 (DH-10 Bench) with Left Head 50-750 IPM (1.25-19.0 m/m) & Right Head 80-1250 IPM (2.00-31.8 m/m) High Speed Ratio set S2 DIP switch as follows: (initial factory setting)

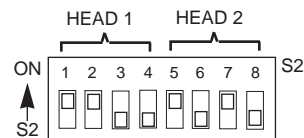

SINGLE HEADS:

For K1563-1 (LN-10 Boom) with 35-500 IPM (0.89-12.7 m/m) **Low Speed Ratio** set S2 DIP Switches as follows:

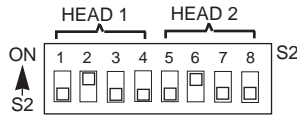

For K1563-1 (LN-10 Boom) with 50-750 IPM (1.25-19.0 m/m) **High Speed Ratio** set S2 DIP Switch as follows: (initial factory setting)



For K1563-2 (LN-10 Boom) with 55-825 IPM (1.40-21.0 m/m) **Low Speed Ratio** set S2 DIP Switch as follows:

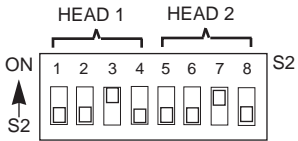

For K1563-2 (LN-10 Boom) 80-1250 IPM (2.00-31.8 m/m) **High Speed Ratio** set S2 DIP Switch as follows: (initial factory setting)

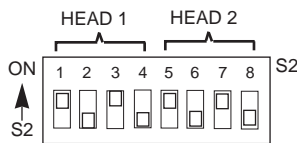

For K679-1 (Single Head Boom) with 50-770 IPM (1.27-19.5 m/m) **Low Speed Ratio** set S2 DIP Switch as follows:

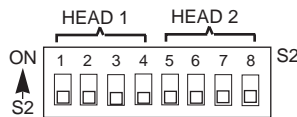

For K679-2 (Single Head Boom) with 80-1200 IPM (2.00-30.5 m/m) **High Speed Ratio** set S2 DIP Switch as follows:

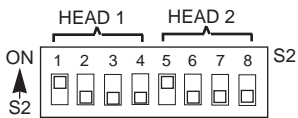

NOTE: Any single drive may be connected to the Head 1 or Head 2 connector. Both settings are configured the same way.

Welding Power Source Selection

The DH-10 Control is set up for proper presettable weld voltage control by setting S1 DIP switches (1 to 4) as appropriate per the following information for the welding power source being used:

CV-250/CV 300-I:

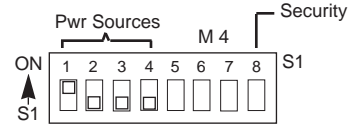

CV-300/CV 400-I:

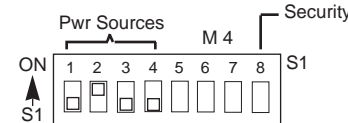

CV-400/CV 500-I:

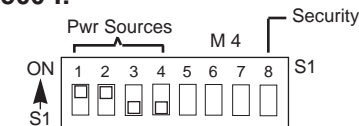

CV-655/DC-655: (initial factory setting)

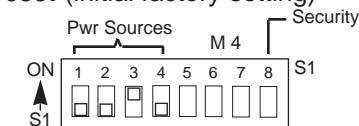

DC-250:

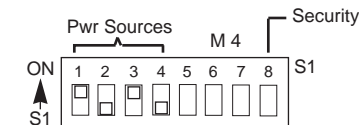

DC-400:

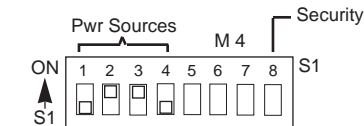

DC-600:



DC-650 PRO:

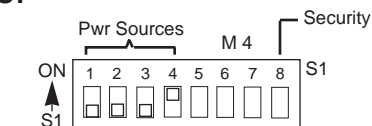

DC-1000:

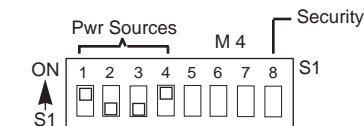

Return to Section TOC (top and bottom edges)

Return to Master TOC (top edge)

Return to Master TOC (middle edge)

Return to Master TOC (middle edge)

Return to Master TOC (bottom edge)

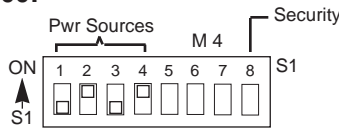
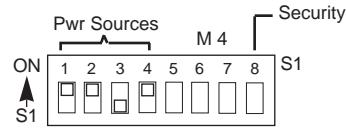
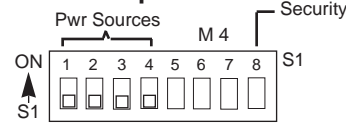
Pulse Power 500:**V300 PRO:****Other Power Source Independent:**

Set the DIP switches as shown for all other power sources which can be controlled with a 10K Ω potentiometer circuit.

All DH-10 features operate as described elsewhere in this manual except for the following differences:

1. Instead of displaying a preset value in volts, the top display will show a number from "0.00" to "10.00" in increments of "0.02". The number can be used for setting run-in "voltage" as well as "weld preset voltage". When the trigger is closed or while welding, the top display will display actual arc voltage. The voltage displayed while welding can be used to determine the arc voltage to be expected for a given number setting. Actual arc voltage display will still flash for 5 seconds after a weld has been completed.
2. If a loss of arc voltage occurs, wire will **NOT** stop feeding. The Loss of Voltage Sense Shutdown feature is disabled to permit the use of the DH-10 with power source connections that do not connect the work voltage back to the DH-10 through the input power cable. The actual weld voltage while welding will **NOT** properly be shown on the top display if the work voltage is not available to the DH-10 through the input power cable.

Metric/English Wire Feed Speed Display Selection

The DH-10 Control is set up for Wire Feed Speed display in Metric units (m/min) or English units (IPM) by setting S1 DIP switch 6 (Labeled "M"):

S1 switch 6 OFF = IPM (as shipped)

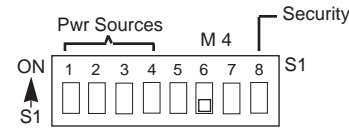

S1 switch 6 ON = m/min

**4-Step Trigger Mode Operation Selection**

The DH-10 Control is set up for 4-Step Trigger mode operation with or without weld current interlock by setting S1 DIP switch 7 (Labeled "4").

When 4-Step trigger mode is selected on the DH-10 keypad (See Keypad and Display Operation in this section) S1 DIP switch setting determines the 4-step trigger operation:

S1 switch 7 OFF = 4-Step with current interlock operation: (As shipped)

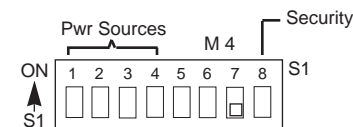

1. Closing Trigger initiates gas preflow time followed by Run-in speed and strike voltage until arc strike initiates welding.
2. Opening Trigger after welding arc is established continues welding with weld current interlock. (Breaking arc stops the feeder operation).
3. Reclosing Trigger continues welding but shuts off current interlock function.
4. Reopening Trigger stops wire feed and initiates burnback time, then gas postflow time.

S1 switch 7 ON = 4-Step without current interlock operation:

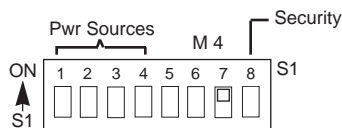

1. Closing Trigger initiates gas flow.
2. Opening Trigger initiates gas preflow timer followed by Run-in speed and strike voltage until arc strike initiates welding. (Trigger is released before arc is struck, but once established breaking arc stops the feeder operation).
3. Reclosing Trigger stops wire feed and initiates burnback time, then gas postflow time.
4. Reopening Trigger stops gas flow if, or when, postflow time is over.

Low Security Mode Selection

The DH-10 Control is set up for Low Security Mode (See "Security Modes" in this section) by setting S1 DIP Switch 8 (Labeled "S"):

S1 switch 8 ON = Low Security mode ON

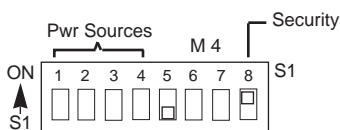

S1 switch 8 OFF = Low Security mode OFF (as shipped)

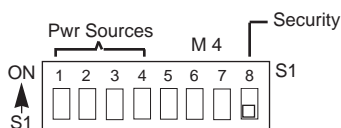

NOTE: High Security mode must be OFF for Low Security mode to function.

High Security Mode Selection

The DH-10 Control is set up for High Security Mode (See **Security Modes** in this section) by setting S1 DIP switch 5 (Not labeled):

S1 switch 5 ON = High Security mode ON

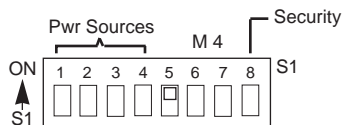

S1 switch 5 OFF = High Security mode OFF (as shipped)

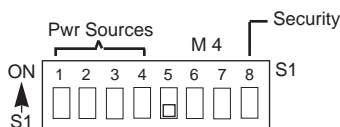

KEYPAD AND DISPLAY OPERATION

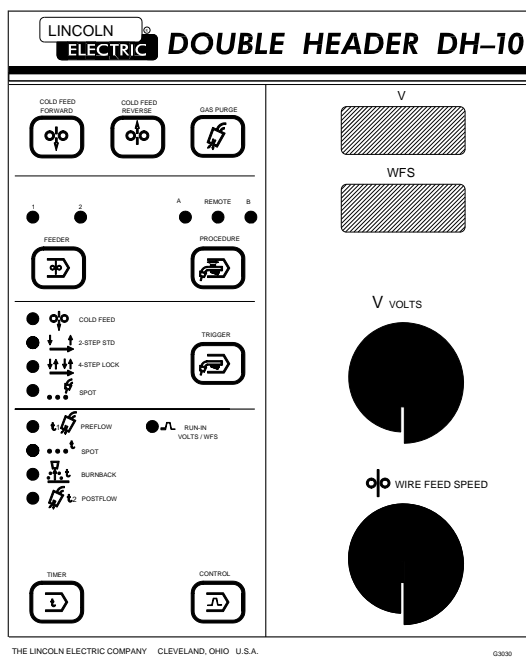

Keypad and Display Description

Keypad - Eight key, membrane type with "snap" tactile feel and embossed domes. Long life design. Spatter resistant surface.

Displays - Two digital LED displays with 0.56 in. (14.2 mm) character height. Top (3-1/2 digit) displays Preset and Actual (while welding) arc voltage in volts with (+) or (-) polarity indicators, and also displays all timers in seconds. Bottom (4 digit) displays preset wire feed speed in IPM, or m/m, and acceleration selection.

Indicator Lights - Extra bright red LEDs for viewing at almost any angle. Always indicate the feeder and procedure selected, trigger mode being used and function or timer being displayed.

Rotating Encoders - Knob controls increase or decrease settings of volts and wire feed speed (initially factory set to minimum). Alternately, the top encoder adjusts timer settings and bottom selects acceleration settings when selected for these parameters to be displayed.

Power-Down Save

Power to the DH-10 is supplied and controlled from the power source. The DH-10 automatically senses the loss of power when the power source is turned off.

Return to Section TOC

Dual procedure settings, including; trigger mode, cold feed speed, Run-in and weld speed and voltage, timers and acceleration are automatically saved for each feeder when power is removed. This feature does not require batteries and when power is restored it will automatically return all settings to the state they were in when power was removed. The operator may overwrite any or all of these settings following power up recall.

Operation Keys

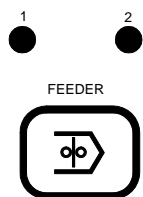

Feeder Lights - Indicate the wire feed head selected for procedure, mode, timer and cold feed functions settings. The feeder may be selected by pressing the Feeder select key, or by the last feeder gun trigger that was closed.

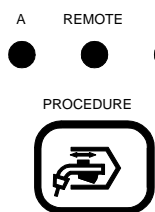

Procedure Lights - Indicate which procedure (A or B) is selected for the selected feeder. A and B procedure for Feeder 1 is independently set from A and B Procedure for Feeder 2. The Procedure select key selects A or B, or if REMOTE Light is selected, the procedure selection light is controlled by connection of an optional Dual Procedure gun switch (K683-1, -3) or Dual Procedure Remote Control (K1449-1).



Cold Feed Keys - energize the wire feeder but not the power source or gas solenoid valve. Cold Feed Forward speed is factory

set at 200 IPM, but is adjustable with WFS encoder knob and displayed on WFS display (with "Cld" shown on the Voltage display) only while pressing Cold Feed Forward, and the last speed set is stored in memory for the next cold feeding, unless changed in Cold Feed trigger mode (see following section). Cold Feed Reverse retracts wire at a fixed 80 IPM speed which is not adjustable.



Gas Purge key - energizes the gas solenoid valve but not the wire feeder or power source.

Trigger Mode Selection

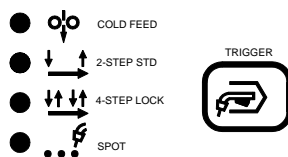

Trigger Mode Select key - enables operator to choose mode of operation shown by the indicator lights. Pressing key causes mode lights to sequence (top to bottom) starting from the current indicated selection.

Top Light - Indicates gun trigger has been selected to perform the Cold Feed Forward function in exactly the same manner as Cold Feed Forward key (See **Operation Keys - Cold Feed Keys**) with the same memory stored adjustable speed setting, and "Cld" shown on the Voltage display.

Second Light - indicates 2-step (standard) trigger mode.

1. Trigger closure energizes the solenoid valve, then the wire feeder and the power source after Preflow time.
2. Releasing the trigger turns off the wire feeder, then power source after burnback time and then the gas solenoid valve after Postflow time.

Third Light - indicates 4-step (lock) trigger mode. This mode may be selected to include or exclude weld current interlock. (See **4-Step Trigger Mode Operation Selection** in this section for 4-step Trigger Mode operation)

Bottom Light - indicates Spot Weld Mode, which will only light if a spot time is set (See **Display Control Keys** in this section). If set to 0.0 seconds, spot mode light selection will be skipped. Trigger closure energizes the gas solenoid valve, then wire feeder and the power source. The spot timer starts when current flows. The wire feeder and power source then solenoid valve are all turned off when the spot on timer times out even though the trigger is opened or is still closed. Preflow/Postflow and burnback timers are also functional in spot mode. (See **Display Control Keys** in this section).

Display Control Keys

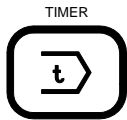

TIMER

Timer Select key - enables operator to choose burnback, spot or gas timers, as indicated by the appropriate light. Pressing the key causes lights to sequence (top to bottom, then all off) starting from the current indicated selection.

When a timer is selected the Voltage display shows the time setting in seconds, as indicated by "SEC" displayed on the speed display. The times are set using the Voltage encoder knob.

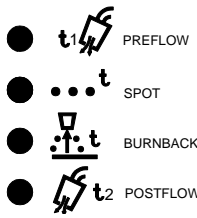

PREFLOW

SPOT

BURNBACK

POSTFLOW

Top Light - indicates preflow time is being displayed, settable 0.0 to 2.5 seconds (0.2 sec as shipped). This is the time the shielding gas flows before the wire feed and power source are activated.

Second Light - indicates spot time is being displayed, settable 0.0 (as shipped) to 199.9 seconds.

Third Light - indicates burnback time is being displayed, settable 0.00 (as shipped) to 0.25 seconds. This is the time the arc power is delayed at the stop of the weld, and should be set to the lowest time required to prevent the wire sticking in the weld.

Bottom Light - indicates postflow time is being displayed, settable 0.0 to 10.0 seconds (0.5 sec as shipped).

This is the time the shielding gas flows after the wire feed and power source are deactivated.

Pressing Timer Select Key again, or closing the gun trigger, shuts all timer lights off, indicating weld Voltage and Wire Feed Speed are again being displayed, and set by the appropriate encoder knob.

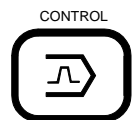

CONTROL



RUN-IN

VOLTS / WFS

Control Select key - enables operator to choose Run-In procedure as indicated by the light turning on. When light is on, the settings of Run-In Wire Feed Speed and Voltage are displayed. After Weld procedure is set, Run-in procedure should be set to optimize arc starting.

Speed encoder knob can adjust run-in speed between min. rated speed and up to the procedure Weld speed setting. Run-in speed setting can not exceed Weld speed setting. Run-in speed setting of 100 IPM or less is recommended for optimum starting. Factory setting is near min. rated speed.

If set below minimum rated speed "---" will show on the WFS display, indicating Run-in speed is set to match weld speed setting.

The Run-in (strike) voltage can be set above or below the Weld voltage setting up to a max of 60 V. If set below a min of 10 V, the Run-In (strike) voltage display shows "---", indicating the Run-In Voltage is set to match the weld voltage setting. Also, the difference between Run-in voltage and Weld voltage settings is maintained automatically if the Weld voltage setting is changed, so the run-in voltage encoder knob does not need to be changed to follow the Weld voltage setting.

When trigger is closed (and preflow time is over) the wire feeds at Run-In speed and volts until the welding arc strikes, which causes the feed speed and volts to change to Weld settings.

If the arc does not strike within about 2 seconds, the Run-In speed automatically changes to Weld speed to permit "Hot" feeding at higher speed setting for loading wire.

Pressing control key again, or closing the gun trigger, shuts off light indicating knob settings and displays are returned to Weld Voltage and Wire Feed Speed.

Digital "Memory" Voltmeter

When the welding gun trigger is activated, the top DH-10 display reads actual welding voltage from 0.0 to 60.0 VDC with automatic polarity indication for positive (+) or negative (-) electrode.

If actual voltage drops below 8.0 volts for over 0.8 sec when the trigger is closed, Loss of Voltage Sense Shutdown will occur. See "Loss of Voltage Sense Shutdown" in this section.

The last welding voltage monitored at the end of the weld is displayed for 5 seconds after the weld has stopped, as indicated by a 5 second "blinking" display. This allows checking actual weld voltage after weld has stopped.

Any keypad or trigger operation will interrupt the 5 second memory display.

Acceleration Selection



GAS PURGE



CONTROL

To provide optimum starting of various processes and procedures, the wire feed acceleration of the DH-10 can be set to five levels; 1 thru 5, for each feeder and procedure. 1 is the slowest acceleration and 5 is the fastest.

To change acceleration hold the Gas Purge Key closed, then press the Control key. The top (Voltage) display shows "Acc" indicating acceleration setting, 1 thru 5, is displayed on the bottom (Speed) display. Use the speed encoder knob to change setting of 1 thru 5.

To exit this function, and enter the acceleration setting into the procedure memory, press both keys again or close the trigger.

Security Modes

Both Low and High Security modes are provided to capture and prevent changing of procedure settings. Both modes are activated, or deactivated by setting S1 DIP switch located inside the DH-10 Control Box.

Low security mode is used to capture timer, acceleration and control selections and settings, then to disable these selections until low security mode is deactivated. Encoder knob setting changes of cold feed, weld speed and weld voltage are not disabled.

Low Security mode is activated, or deactivated, by shutting off the input power to the DH-10 with all Timer and Control settings as desired for both procedures for both Feeders. Then setting S1 DIP switch 8 inside the DH-10 Control Box ON or OFF and restoring input power (See **Low Security Mode Selection** in this section).

When activated, the Timer and Control selections no longer light, but function with the captured settings. All other keys and encoder knob controls function normally.

NOTE: High Security mode must be OFF for Low Security mode to function.

High Security mode functions the same as Low Security mode, but the Voltage and Wire Feed Speed encoder knob controls are also deactivated, including setting Cold Feed Speed (See **Operation Keys** and **Trigger Mode Selection** in this section).

High Security mode can only be activated, or deactivated, by shutting off the input power to the DH-10 with all settings as desired for both Procedures for both Feeders. Then setting S1 DIP Switch 5, inside the DH-10 Control Box, ON, or OFF, and restoring input power. (See **High Security Mode Selection** in this section).

DUAL PROCEDURE REMOTE CONTROL (K1449-1)

When this option is connected to the DH-10 Control Box receptacle, and the Procedure Key selects "REMOTE" the front panel knob controls and procedure selection is transferred to the knob encoder controls and Procedure Selector Switch of the remote, which function in the exact same manner. Remote knob encoders set Weld voltage and wire feed speed, as well as Trigger Cold Feed Speed, but not Timers or Run-In.

If using the optional K683-1, -3 Dual Procedure Switch, for either or both wire drives, to select A or B along with the (K1449-1) remote, both the front panel and remote Procedure selector and switch must be set to "REMOTE" and "Gun Switch" (center) positions.

The DH-10 Procedure lights indicate whether A or B is remotely selected.

WIRE REEL LOADING - READI-REELS, SPOOLS OR COILS To Mount a 30 lb (14 kg) Readi-Reel Package (Using the Molded Plastic K363-P Readi-Reel Adapter) (FIGURE B.1):

The Spindle should be located in the **LOWER** mounting hole.

1. Depress the Release Bar on the Retaining Collar and remove it from the spindle.
2. Place the Adapter on the spindle.
3. Re-install the Retaining Collar. Make sure that the Release Bar "pops up" and that the collar retainers fully engage the retaining groove on the spindle.
4. Rotate the spindle and adapter so the retaining spring is at the 12 o'clock position.
5. Position the Readi-Reel so that it will rotate in a direction when feeding so as to be de-reeled from bottom of the coil.
6. Set one of the Readi-Reel inside cage wires on the slot in the retaining spring tab.
7. Lower the Readi-Reel to depress the retaining spring and align the other inside cage wires with the grooves in the molded adapter.
8. Slide cage all the way onto the adapter until the retaining spring "pops up" fully.

DH-10

LINCOLN
ELECTRIC

⚠ CAUTION

Check to be sure the Retaining Spring has fully returned to the locking position and has SECURELY locked the Readi-Reel Cage in place. Retaining Spring must rest on the cage, not the welding electrode.

- To remove Readi-Reel from Adapter, depress retaining spring tab with thumb while pulling the Readi-Reel cage from the molded adapter with both hands. Do not remove adapter from spindle.

FIGURE B.1 — READI-REEL MOUNTING.

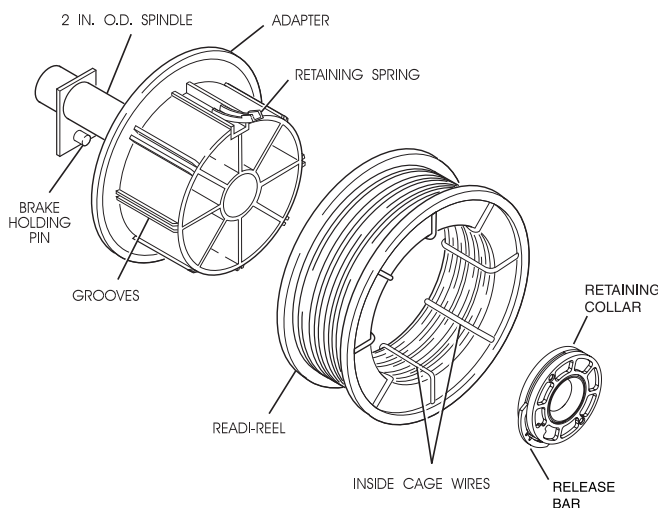

To Mount 10 to 44 lb (4.5 to 20 kg) Spools (12 in/300 mm Diameter) or 14 lb (6 kg) Innershield Coils (FIGURE B.1):

The Spindle should be located in the **LOWER** mounting hole.

(For 8 in. (200 mm) spools, a K468 spindle adapter must first be slipped onto spindle.)

(For 13-14 lb. (6 kg) Innershield coils, a K435 Coil Adapter must be used).

- Depress the Release Bar on the Retaining Collar and remove it from the spindle.
- Place the spool on the spindle making certain the spindle brake pin enters one of the holes in the back side of the spool. Be certain the wire comes off the reel in a direction so as to de-reel from the bottom of the coil.
- Re-install the Retaining Collar. Make sure that the Release Bar “pops up” and that the collar retainers fully engage the retaining groove on the spindle.

To Mount a 50 to 60 lb (22.7 to 27.2 kg) Coil: (Using K1504-1 Coil Reel) (For 50 to 60 lb Readi-Reels a K438 Readi-Reel Adapter must be used).

The Spindle must be located in the **UPPER** mounting hole.

- With the K1504-1 Coil Reel mounted on to the 2 in. (51 mm) spindle (or with reel laying flat on the floor) loosen the spinner nut and remove the reel cover. (See Figure B.2).
- Before cutting the tie wires, place the coil of electrode on the reel so it unwinds from the bottom as the reel rotates.
- Tighten the spinner nut against the reel cover as much as possible by hand using the reel cover spokes for leverage. **DO NOT** hammer on the spinner nut arms.
- Cut and remove only the tie wire holding the free end of the coil. Hook the free end around the rim of the reel cover and secure it by wrapping it around. Cut and remove the remaining tie wires.

⚠ CAUTION

Always be sure the free end of the coil is securely held while the tie wires are being cut and until the wire is feeding through the drive rolls. Failure to do this will result in “backlashing” of the coil, which may tangle the wire. A tangled coil will not feed so it must either be untangled or discarded.

- Be sure the coil reel is engaged with the spindle brake pin and the Release Bar on the Retaining Collar “pops up” and that the collar retainers fully engage the retaining groove on the spindle.

FIGURE B.2 — K1504-1 COIL REEL.

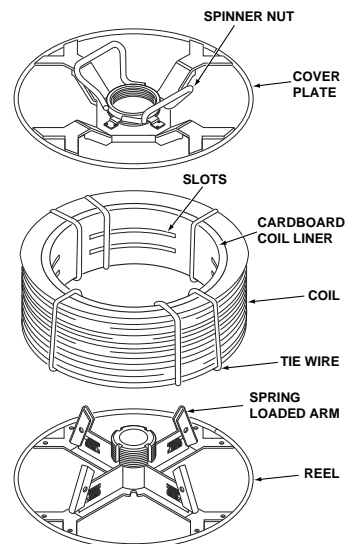

FEEDING ELECTRODE AND BRAKE ADJUSTMENT

1. Turn the Reel or spool until the free end of the electrode is accessible.
2. While tightly holding the electrode, cut off the bent end and straighten the first 6 in. (150 mm). Cut off the first 1 in. (25 mm). (If the electrode is not properly straightened, it may not feed or may jam causing a "birdnest".)
3. Insert the free end through the incoming guide tube.
4. Press the Cold Inch key or the Cold Feed Mode gun trigger and push the electrode into the drive roll.

WARNING

When feeding with the gun trigger, unless "COLD FEED" trigger mode is selected, the electrode and drive mechanism are always "HOT" to work and ground and could remain "HOT" several seconds after the gun trigger is released.

5. Feed the electrode through the gun.
6. Adjust the brake tension with the thumbscrew on the spindle hub, until the reel turns freely but with little or no overrun when wire feeding is stopped. Do not overtighten.

DRIVE ROLL PRESSURE SETTING

The DH-10 pressure is factory pre-set to about position "2" as shown on the pressure indicator on the front of the feedplate door. This is an approximate setting.

The optimum drive roll pressure varies with type of wire, surface condition, lubrication, and hardness. Too much pressure could cause "birdnesting", but too little pressure could cause wire feed slippage with load and/or acceleration. The optimum drive roll setting can be determined as follows:

1. Press end of gun against a solid object that is electrically isolated from the welder output and press the gun trigger for several seconds.

2. If the wire "birdnests", jams, or breaks at the drive roll, the drive roll pressure is too great. Back the pressure setting out turn, run new wire through gun, and repeat above steps.
3. If the only result is drive roll slippage, disengage the gun, pull the gun cable forward about 6 in. (150 mm). There should be a slight waviness in the exposed wire. If there is no waviness, the pressure is too low. Increase the pressure setting turn, reconnect the gun, tighten locking clamp and repeat the above steps.

PROCEDURE FOR SETTING ANGLE OF FEEDPLATE

1. Loosen the clamping collar screw using a 3/16 in. Allen wrench. The clamping collar screw is accessed from the bottom of the feedplate. It is the screw which is perpendicular to the feeding direction.
2. Rotate feedplate to the desired angle and tighten clamping collar screw.

GAS GUARD REGULATOR SETTING

1. With the gas supply shut off, the Gas Guard regulator flow adjusting Key should be set to maximum (full clockwise) which is rated to be 60 SCFH (28 l/min).
2. Adjust gas supply flow rate for a level higher than will be required, then adjust Gas Guard flow adjusting Key counterclockwise to the desired gas flow rate.

MAKING A WELD

1. Use only a Lincoln Electric recommended constant voltage DC power source compatible with the DH-10 Wire Feeder.
2. Properly connect the electrode and work leads for the correct electrode polarity.
3. Use the Trigger Mode Selection key to set desired trigger mode for each feeder head and procedure. (Refer to **Trigger Mode Selection** in this section.)

4. Use Control Select and encoder knobs to set desired Weld feed speed and voltage then Run-in speed and voltage to optimize arc starting. (Set for each procedure if using front panel, remote control or optional dual procedure switch.) (Refer to **Operation Keys** and **Display Control Keys** in this section.)
5. Adjust the wire feed acceleration, if desired, for each feeder and procedure. (Refer to **Acceleration Selection** in this section.)
6. Use Timer Select and Voltage Encoder knob to set desired timers. (Refer to **Trigger Mode Selection** in this section.)
7. Feed the electrode through the gun and cable and then cut the electrode within approximately 0.38 in. (9.5 mm) of the end of the contact tip for solid wire and within approximately 0.75 in. (19 mm) of the extension guide for cored wire.
8. Connect work cable to metal to be welded. Work cable must make good electrical contact to the work. The work must also be grounded as stated in **Arc Welding Safety Precautions**.

WARNING



When using an Open Arc process, it is necessary to use correct eye, head, and body protection.

9. If used, be sure shielding gas valve is turned on.
10. Position electrode over joint. End of electrode may be lightly touching the work.
11. Lower welding helmet, close gun trigger, and start welding. Hold the gun so the contact tip to work distance gives the correct electrical stickout as required for the procedure being used.
12. To stop welding, release the gun trigger and then pull the gun away from the work after the arc goes out and Postflow time, if used, is over.
13. If necessary to optimize arc starting, readjust wire speed acceleration, (Refer to **Acceleration Selection** in this section) and/or Run-In speed, (Refer to **Display Control Keys** in this section).

WIRE REEL CHANGING

At the end of a coil, remove the last of the old electrode coil from the conductor cable by either pulling it out at the nozzle end of the gun or by using the following procedure:

1. Cut the end of the electrode off at the gun end. Do not break it off by hand because this puts a slight bend in the wire making it difficult to pull it back through the nozzle.
2. Disconnect the gun cable from the gun connector on the DH-10 wire drive unit and lay the gun and cable out straight.
3. Using pliers to grip the wire, pull it out of the cable from the connector end.
4. After the electrode has been removed, reconnect the gun cable to the drive. Load a new reel of electrode per the instructions in **Wire Reel Loading** in this section.

LOSS OF VOLTAGE SENSE SHUTDOWN

If the actual displayed voltage, when the trigger is closed, drops below 8.0 volts for over 0.8 second it is assumed the voltage feed back sensing circuit to the DH-10 is opened or faulty, so Loss of Voltage Sense Shutdown occurs until the trigger is released.

This shutdown stops the motor, shuts off the gas flow and disables the power source output to prevent the DH-10 voltage control from driving the power source output too high due to loss of proper feedback sensing via #21 (WORK) and #67 (ELECTRODE) sensing leads.

WIRE FEED OVERLOAD PROTECTION

The DH-10 has solid-state overload protection of the wire drive motor. If the wire drive motor becomes overloaded for an extended period of time, the protection circuitry turns off the power source, wire feed and gas solenoid, and then displays "H30" on the WFS display (with blank Voltage display). This indicates the wire drive motor is overloaded and will remain shut down for about 30 seconds before the unit will automatically reset. The "H30" display decrements every second until it reaches "H00". At that time, the unit resets automatically and the previous displays will return indicating the unit is ready to operate again. Overloads can result from improper tip size, liner, drive rolls, or guide tubes, obstructions or bends in the gun cable, feeding wire that is larger than the rated capacity of the feeder or any other factors that would impede normal wire feeding. (See **Avoiding Wire Feeding Problems** in the **Maintenance** section).

DH-10



GROUNDING LEAD PROTECTOR

The frame of the DH-10 Control is grounded to the frame of the power source by a lead in the control cable. An overload protector prevents welding current from damaging this lead if the electrode circuit touches the wire feeder frame while the electrode is electrically hot.

If such a grounding lead fault occurs, the WFS display will show "GLP," (with blank Voltage display) and the trigger circuit will be disabled. To reset the circuit, release the trigger, make sure that the electrode is not touching the wire feeder frame, and then either press any key on the keypad or close the trigger. When the GLP circuit is reset, the "GLP" display is removed and the wire feeder is returned to normal operating mode.

EXPLANATION OF PROMPTING AND ERROR MESSAGES

Display Prompt or Error

Acc Displayed on Voltage display, indicates WFS display is showing acceleration setting, "1" to "5" (see **Acceleration Selection** in this section).

SEC Displayed on WFS display, indicates Voltage display is showing a Timer setting in seconds. (See **Display Control Keys** in this section.)

GLP Displayed on WFS display, indicates that the Grounding Lead Protector circuit was activated due to excessive current flow into the wire feeder frame. When the GLP circuit

is activated the wire feeder is disabled (the trigger output to the power source is opened up, the motor is stopped, and the gas solenoid is turned off). To resume normal operation, release the trigger, make sure that the electrode is not touching the wire feeder frame, and then either press a key on the keypad or close the trigger. (See **Grounding Lead Protector** in this section.)

Cld Displayed on Voltage display when Cold Feed Forward or Cold Feed Reverse Key is pressed, or Cold Feed Trigger mode is selected. Indicates wire is fed "cold" (no weld voltage) at the speed indicated on the WFS display. (See **Operation Keys** and **Trigger Mode Selection** in this section.)

--- Displayed on Voltage or WFS displays with RUN-IN selected, indicates setting will match those set for Weld Voltage and Wire Feed Speed. (See **Display Control Keys** in this section.)

HXX Displayed on WFS display, indicates wire feed overload. XX indicates time remaining in seconds before unit resets automatically. (See **Wire Feed Overload Protection** in this section and **Avoiding Wire Feeding Problems** in the **Maintenance** section.)

Er EEPROM error. Usually occurs at power-up. Indicates one or more of the recalled settings is out of acceptable limits. Press any key to return to normal operation. Be sure to check all voltage, wire feed speed, acceleration and timer settings before you proceed.

TABLE OF CONTENTS
-ACCESSORIES SECTION-

Accessories	Section C
General	C-2
Drive Roll and Guide Tube Kits	C-3
Input Cable Assemblies	C-4
Spindle Adapters	C-4
Gun Adapters (For DH Wire Drive Heads)	C-5
Gun and Cable Assemblies	C-5

Return to Master TOC

Return to Master TOC

Return to Master TOC

Return to Master TOC

GENERAL

The following is a list of all the accessories that can be used with the DH-10 Dual Head Wire Feeder. A description of each item is given later in the section.

TABLE C.1 — DH-10 DUAL HEAD WIRE FEEDER ACCESSORIES.

KP1505 Series	DRIVE ROLL AND GUIDE TUBE KITS
KP1507 Series	DRIVE ROLL AND GUIDE TUBE KITS
KP655 Series	DRIVE ROLL AND GUIDE TUBE KITS
KP656 Series	DRIVE ROLL AND GUIDE TUBE KITS
KP647 Series	DRIVE ROLL AND GUIDE TUBE KITS
K1501	INPUT CABLE ASSEMBLY (CONTROL CABLE ONLY)
K1502	INPUT CABLE ASSEMBLY
K1503	INPUT CABLE ASSEMBLY
K1520-1	155V/42V TRANSFORMER KIT
K590-4	WATER CONNECTION KIT
K659-1	GAS GUARD REGULATOR
K1449-1	DUAL PROCEDURE REMOTE CONTROL
K1450-"L"	EXTENSION CABLE ("L" REPRESENTS 12, 16, OR 25 FT. (3.6, 4.9, OR 7.6M))
K683-1	DUAL PROCEDURE SWITCH
K683-3	DUAL PROCEDURE SWITCH
K162H	SPINDLE ADAPTER
K1504-1	COIL ADAPTER
K435	COIL ADAPTER
K468	COIL ADAPTER
K363P	READI-REEL ADAPTER
K438	READI-REEL ADAPTER
K1500-1	GUN ADAPTER
K1500-2	GUN ADAPTER
K1500-3	GUN ADAPTER
K126	INNERSHIELD GUN AND CABLE ASSEMBLY
K115	INNERSHIELD GUN AND CABLE ASSEMBLY
K470	MAGNUM 300 GMAW GUN AND CABLE ASSEMBLY
K471	MAGNUM 400 GMAW GUN AND CABLE ASSEMBLY
K497	MAGNUM 200 GMAW GUN AND CABLE ASSEMBLY
K541	MAGNUM 400 SHORT NECK GMAW GUN AND CABLE ASSEMBLY
K598	MAGNUM 550 GMAW GUN AND CABLE ASSEMBLY
K684	MAGNUM "SUPER COOL" FM WATER COOLED GMAW GUN AND CABLE ASSEMBLY
K498	MAGNUM 200 FM GMAW GUN AND CABLE ASSEMBLY
K534	MAGNUM 250L FM GMAW GUN AND CABLE ASSEMBLY
K478	MAGNUM 300 FM GMAW GUN AND CABLE ASSEMBLY
K479	MAGNUM 400 FM GMAW GUN AND CABLE ASSEMBLY

DRIVE ROLL AND GUIDE TUBE KITS

Table C.2 gives a listing of all of the Drive Roll and Guide Tube Kits that are available for the DH-10 Dual Head Wire Feeder.

TABLE C.2 — DRIVE ROLL AND GUIDE TUBE KITS.

Wire Size	4-Roll DH Drive (4-Driven)	4-Roll Single Drive (2-Driven)
<u>Solid Steel Electrode</u>		
0.023 in. - 0.025 in. (0.6 mm)	KP1505 - 030S	KP655 - 025S
0.030 in. (0.8 mm)	KP1505 - 030S	KP655 - 030S
0.035 in. (0.9 mm)	KP1505 - 035S	KP655 - 035S
0.040 in. (1.0 mm)	KP1505 - 045S	KP655 - 035S
0.045 in. (1.2 mm)	KP1505 - 045S	KP655 - 052S
0.052 in. (1.4 mm)	KP1505 - 052S	KP655 - 052S
1/16 in. (1.6 mm)	KP1505 - 1/16S	KP655 - 1/16
5/64 in. (2.0 mm)	KP1505-5/64	KP655 - 3/32
3/32 in. (2.4 mm)	KP1505-3/32	-----
<u>Cored Electrode</u>		
0.030 in. (0.8 mm)	KP1505 - 035C	-----
0.035 in. (0.9 mm)	KP1505 - 035C	KP655 - 035C
0.040 in. (1.0 mm)	KP1505 - 045C	KP655 - 035C
0.045 in. (1.2 mm)	KP1505 - 045C	KP655 - 052C
0.052 in. (1.4 mm)	KP1505 - 052C	KP655 - 052C
1/16 in. (1.6 mm)	KP1505 - 1/16C	KP655 - 1/16
0.068 in. (1.7 mm)	KP1505 - 068	KP655 - 3/32
5/64 in. (2.0 mm)	KP1505 - 5/64	KP655 - 3/32
3/32 in. (2.4 mm)	KP1505 - 3/32	-----
7/64 in. Lincore Hard Facing (2.8 mm)	KP1505 - 7/64H	-----
7/64 in. (2.8 mm)	KP1505 - 7/64	-----
0.120 in. (3.0 mm)	KP1505 - 120	-----
<u>Aluminum Electrode</u>		
0.035 in. (0.9 mm)	KP1507 - 035A	KP656 - 035A
0.040 in. (1.0 mm)	KP1507 - 040A	-----
3/64 in. (1.2 mm)	KP1507 - 3/64A	KP656 - 3/64A
1/16 in. (1.6 mm)	KP1507 - 1/16A	KP656 - 1/16A
3/32 in. (2.2 mm)	KP1507 - 3/32A	-----
<u>Aluminum Electrode</u>		
<u>(For use with Binzel Guns Only)</u>		
0.040 in. (1.0 mm)	-----	KP647 - 040A
3/64 in. (1.2 mm)	-----	KP647 - 3/64A
1/16 in. (1.6 mm)	-----	KP647 - 1/16A

INPUT CABLE ASSEMBLIES

(One required per DH-10 Control Box.)

K1501 (Control Cable Only) - Consists of a 9-conductor control cable with a 14-pin control cable plug, without electrode cable, and is available in lengths of 10 ft (3 m), 17 ft (5 m), 25 ft (7.6 m), 33 ft (10 m), 50 ft (15 m) and 100 ft (30 m).

K1502 - Consists of a 9-conductor control cable with a 14-pin plug and a 3/0 (85 mm²) electrode cable with stud terminal. It is rated at 600 amps, 60% duty cycle and is available in lengths of 10 ft (3 m), 17 ft (5 m), 25 ft (7.6 m), 33 ft (10 m) and 50 ft (15 m) and 100 ft (30 m) is also available with a 4/0 (107 mm²) electrode cable.

K1503 - Consists of a 9-conductor control cable with a 14-pin plug and 2/0 (67 mm²) electrode cable with Twist-Mate™ connector. It is rated at 500 amps, 60% duty cycle and is available in lengths of 10 ft (3 m), 17 ft (5 m), 25 ft (7.6 m), 33 ft (10 m) and 50 ft (15 m) and 100 ft (30 m) is also available with a 3/0 (85 mm²) electrode cable.

K1520-1 115V/42V TRANSFORMER KIT

Required to use DH-10 with Lincoln Power Sources without 42VAC auxiliary and a 14-pin connector receptacle. These power sources include the DC-250, DC-600, DC-1000 and Pulse Power 500. Also can be used with older DC-400 models.

K590-4 WATER CONNECTION KIT

(One per gun) Includes water cooled gun tube fittings and self-sealing outlet and inlet quick-connectors for mounting into the DH wire drive connection box.

K659-1 GAS GUARD REGULATOR

(One per gun) Adjustable flow regulator with removable adjuster key for CO₂ and Argon blend gases. Mounts onto wire drive gas inlet, and reduces gas waste and arc start "blow" by reducing surge caused by excess pressure in supply hose.

K1449-1 DUAL PROCEDURE REMOTE CONTROL

(One per DH-10 Control Box) Includes a remote control box with a 16 ft (5 m) length control cable with 4-pin plug for the mating receptacle on the bottom of the DH-10 control box. The remote control box contains a procedure selector switch and 2 rotating knob encoders, one controls arc voltage and the other controls wire feed speed, which function the same as comparable controls on the DH-10 front panel, when the remote is connected and selected by the DH-10 Procedure Key.

K1450-"L" - Extension cables are available in lengths "L" of 12, 16 or 25 ft (3.6, 4.9 or 7.6 m) to match the control to Feeder cable length used.

K1558-1 - Remote Switch Interface Module, can be used with the DH-10, using a G3041-2 (or higher) Control Board. The module provides for user interface connection of an external switch (flow switch, etc) which must be closed to enable the feeder welding operation. Also, the module provides for interface connection of external equipment (fume extractor, etc.) To the module's isolated relay contacts which actuate when the feeder welding gas solenoid is activated (representing welding operation in process).

When used with the DH-10, the module provides these input and output switch function connections independently for each head operation.

This module is necessary when using the K1536-1 waterflow sense kit with the DH-10.

K683-1 DUAL PROCEDURE SWITCH

(One per gun) - Requires K686-2 Adapter for DH-10. Kit includes gun switch, and mountings for Lincoln Innershield and Magnum guns, with 15 ft (4.5 m) control cable and 3-pin plug. K686-2 Adapter permits 3-pin plug and 5-pin gun trigger plug to be connected to DH-10 5-pin Trigger/Dual Procedure receptacle.

K683-3 DUAL PROCEDURE SWITCH

(One per gun) Kit includes gun switch, and mountings for Lincoln Innershield and Magnum guns, with 15 ft (4.5 m) control cable and 5-pin plug with two leads to connect to gun trigger.

SPINDLE ADAPTERS

K162H - (Not required for DH-10 Bench Models) Spindle for boom mounting Readi-Reels and 2 in. (51 mm) I.D. spools with 60 lb (27.2 kg) capacity. User mounted to appropriately prepared boom framework. Includes an easily adjustable friction brake for control of overrun.

When a 2 in. (51 mm) spindle is used with Readi-Reels or coils not on 12 in. (305 mm) O.D. spools, an adapter is required:

Coil Adapters

K1504-1 - Permits 50 lb to 60 lb (22.7-27.2 kg) Coils to be mounted on 2 in. (51 mm) O.D. spindles.

K435 - Permits 14 lb (6 kg) Innershield coils to be mounted on 2 in. (51 mm) O.D. spindles.

K468 - Permits 8 in. (203 mm) O.D. spools to be mounted on 2 in. (51 mm) O.D. spindles.

Readi-Reel Adapters

K363P - Adapts Lincoln Readi-Reel coils of electrode 30 lb (14 kg) and 22 lb (10 kg) to a 2 in. (51 mm) spindle. Durable molded plastic one piece construction. Designed for easy loading; adapter remains on spindle for quick changeover.

K438 - Adapts Lincoln Readi-Reel coils of electrode 50 to 60 lb. (22.7 to 27.2 kg) to a 2 in. (51 mm) spindle.

GUN ADAPTERS (FOR DH WIRE DRIVE HEADS)

Adapts DH heads for desired gun connection:

K489-7 for Fast-Mate (or European style) gun connections, including Dual Schedule Fast-Mate guns.

K1500-1 for standard Lincoln Innershield gun connection, or with Fast-Mate™ guns with K489-2 Fast-Mate Adapter Kit. Also for Magnum 200/300/400 with K466-1 connection kit, or Magnum 550 with K613-1.

K1500-2 for Magnum 200/300/400 gun with K466-10 connection kit. (Also Tweco 4.)

K1500-3 for Magnum 550 gun with K613-7 connection. (Also Tweco 5.)

GUN AND CABLE ASSEMBLIES

The following Lincoln gun and cable assemblies are compatible with DH Wire Feed heads with appropriate K1500 Gun Adapter:

K126 (Requires K1500-1) Innershield gun and cable assemblies are rated at 350 amps, 60% duty cycle. (Consult sales specifications for appropriate models.)

K115 (Requires K1500-1) Innershield gun and cable assemblies are rated at 450 amps, 60% duty cycle. (Consult sales specifications for appropriate models.)

K470 (With K466-9 requires K1500-2) Magnum 300 GMAW gun and cable assemblies are rated 300 amps, 60% duty cycle. (Consult sales specifications for appropriate models.)

K471 (With K466-9 requires K1500-2) Magnum 400 GMAW gun and cable assemblies are rated 400 amps, 60% duty cycle. (Consult sales specifications for appropriate models.)

K497 (With K466-9 requires K1500-2) Magnum 200 GMAW gun and cable assemblies are rated 200 amps, 60% duty cycle. (Consult sales specifications for appropriate models.)

K541 (With K466-9 requires K1500-2) Magnum 400 Short Neck GMAW gun and cable assemblies are rated 400 amps, 60% duty cycle. (Consult sales specifications for appropriate models.)

K598 (With K613-7 requires K1500-3) Magnum 550 GMAW gun and cable assemblies are rated 550 amps, 60% duty cycle. (Consult sales specifications for appropriate models.)

The following Lincoln gun and cable assemblies are equipped with a Fast-Mate™ connector. They can be used with DH wire feed models by installing a K489-7 Adapter, or a K489-2 Fast-Mate™ adapter kit and a K1500-1 Lincoln Gun adapter.

K684 Magnum "Super Cool" FM water cooled GMAW gun and cable assemblies are rated 450 amps, 100% duty cycle (CO₂). (Consult sales specifications for appropriate models.)

K498 Magnum 200 FM GMAW gun and cable assemblies are rated for 200 amps 60% duty cycle. (Consult sales specifications for appropriate models.)

K534 Magnum 250L FM GMAW gun and cable assemblies are rated for 250 amps, 30% duty cycle. (Consult sales specifications for appropriate models.)

K478 Magnum 300 FM GMAW gun and cable assemblies are rated for 300 amps, 60% duty cycle. (Consult sales specifications for appropriate models.)

K479 Magnum 400 FM GMAW gun and cable assemblies are rated for 400 amps, 60% duty cycle. (Consult sales specifications for appropriate models.)

K1557-1 SWIVEL MOUNT

The K1557-1 Swivel mount attaches to the power source. This kit includes a feeder adapter plate that allows the feeder to rotate on top of the power source. The feeder can be easily separated from the swivel mount at any time. This option is compatible with the K1556-1 Light Duty Caster Kit.

DH-10

LINCOLN[®]
ELECTRIC

K1556-1 LIGHT DUTY CASTER KIT

This option provides 4 casters and all required hardware to mount it to the Power Feed 10. This option is compatible with the K1557-1 Swivel Mount.

K1555-1 INSULATED LIFT HOOK

For applications where an insulated lift hook is required. This kit provides an easily installed, heavy duty insulated lift eye that mounts to the wire reel stand mast. See the instructions provided with the kit for installation.

K1634-1 WIRE REEL ENCLOSURE KIT

Provides the necessary parts to cover the wire and protect it from excessive dirt and contamination. This kit is **not** for use with 60 lb coils (most 30 lb, 15 kg, 44 lb fiber spools, and smaller coils will work) The kit includes a 2-part reel cover, a Magnum conduit adapter for the incoming end of the wire feeder feed plate and a short length of Magnum conduit to go between the reel cover and the feedplate.

Return to Section TOC

Return to Master TOC

Return to Section TOC

Return to Master TOC

Return to Section TOC

Return to Master TOC

Return to Section TOC

Return to Master TOC

TABLE OF CONTENTS
-MAINTENANCE SECTION-

Maintenance	Section D
Safety Precautions	D-2
Routine Maintenance	D-2
Drive Rolls and Guide Tubes	D-2
Wire Reel Mounting - Readi-Reels and 10 to 30 lb (4.5 to 14 kg) Spools	D-2
Avoiding Wire Feeding Problems	D-2
Periodic Maintenance	D-3
Wire Drive Motor and Gearbox	D-3
Gun and Cable Maintenance	D-3
Procedure for Removing Feedplate from Wire Feeder	D-3

Return to Master TOC

Return to Master TOC

Return to Master TOC

Return to Master TOC

SAFETY PRECAUTIONS

⚠ WARNING



ELECTRIC SHOCK can kill.

- Do not touch electrically live parts such as output terminals or internal wiring.
- When inching with gun trigger, electrode and drive mechanism are “hot” to work and ground and could remain energized several seconds after the gun trigger is released.
- Turn OFF input power at welding power source before installation or changing drive roll and/or guide tubes.
- Welding power source must be connected to system ground per the National Electrical Code or any applicable local codes.
- Only qualified personnel should perform this installation.

Observe all additional Safety Guidelines detailed throughout this manual.

ROUTINE MAINTENANCE

Drive Rolls and Guide Tubes

After feeding every coil of wire, inspect the drive roll section. Clean it as necessary. Do not use a solvent for cleaning the idle roll because it may wash the lubricant out of the bearing. The driver roll and guide tubes are stamped with the wire sizes they will feed. If a wire size other than that stamped on the roll(s) is to be used, the roll(s) and guide tubes must be changed.

The drive rolls for 0.035 in. (0.9 mm) through 0.052 in. (1.3 mm) cored electrode and 1/16 in. (1.6 mm) through 3/32 in. (2.4 mm) electrode have a double set

of teeth so they can be reversed for additional life. Drive rolls for 0.023 in. (0.6 mm) through 0.052 in. (1.3 mm) solid electrodes and aluminum sizes have no teeth, but use two grooves so they also can be reversed for additional life.

See *Procedure to Install Drive Roll and Guide Tubes* in the *Installation* section for roll changing instructions.

WIRE REEL MOUNTING - READI-REELS AND 10 TO 30 lb (4.5 TO 14 kg) SPOOLS

No routine maintenance required. Do not lubricate 2 in. (51 mm) spindle.

AVOIDING WIRE FEEDING PROBLEMS

Wire feeding problems can be avoided by observing the following gun handling and feeder set up procedures:

- Do not kink or pull cable around sharp corners.
- Keep the electrode cable as straight as possible when welding or loading electrode through cable.
- Do not allow dolly wheels or trucks to run over cables.
- Keep cable clean by following maintenance instructions.
- Use only clean, rust-free electrode. The Lincoln electrodes have proper surface lubrication.
- Replace contact tip when the arc starts to become unstable or the contact tip end is fused or deformed.
- Do not use excessive wire spindle brake settings.
- Use proper drive rolls, guide tubes and drive roll pressure settings.

PERIODIC MAINTENANCE

Wire Drive Motor and Gearbox

Every year inspect the gearbox and coat the gear teeth with a moly-disulfide filled grease. Do not use graphite grease.

Every six months check the motor brushes. Replace them if they are less than 1/4 in. long.

Gun and Cable Maintenance

See appropriate Operator's Manual.

PROCEDURE FOR REMOVING FEEDPLATE FROM WIRE FEEDER

1. Loosen the clamping collar screw using a 3/16 in. Allen wrench. The clamping collar screw is accessed from the bottom of the feedplate. It is the screw which is perpendicular to the feeding direction.
2. Loosen the retaining screw, which is also accessed from bottom of feeder, using a 3/16 in. Allen wrench. Continue to loosen the screw until the feedplate can be easily pulled off of the wire feeder.

Return to Section TOC

Return to Master TOC

Return to Section TOC

Return to Master TOC

Return to Section TOC

Return to Master TOC

Return to Section TOC

Return to Master TOC

Return to Section TOC	Return to Section TOC	Return to Section TOC	Return to Section TOC
Return to Master TOC	Return to Master TOC	Return to Master TOC	Return to Master TOC

TABLE OF CONTENTS
- THEORY OF OPERATION SECTION -

Table with 2 columns: Description and Page Number. Rows include Theory of Operation (Section E), General Description (E-2), Input Receptacle, Control Board, and Operator Controls (E-3), and Wire Feed Heads and Receptacles (E-4).

Return to Master TOC

Return to Master TOC

Return to Master TOC

Return to Master TOC

FIGURE E.1 — GENERAL DESCRIPTION.

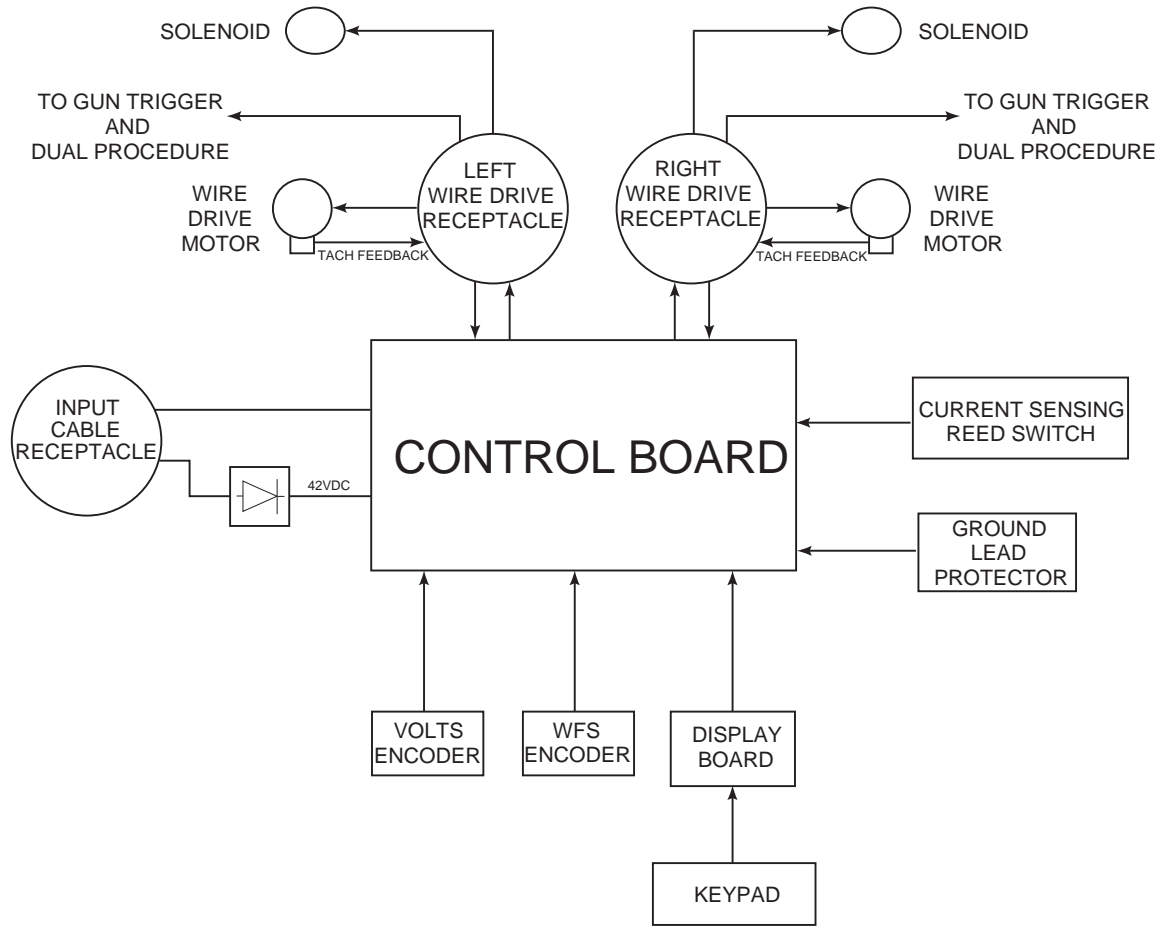

GENERAL DESCRIPTION

The DH-10 is a 42 VAC, dual head, 4-roll wire feeder. A single control for each head is utilized, with dual procedure presettability of wire feed speed and arc voltage. The DH-10 models have controls providing keypad or remote selectability of wire drive head and either one or two procedures for each head. Also

offered are four independently selectable gun trigger modes for each head procedure; cold feed, 2-step and 4-step trigger, and spot weld. The user can also pre-set timers for each head procedure: preflow, postflow, burnback, and spot weld times. Five selectable wire feed acceleration rates can be used to optimize arc starting. Refer to Figure E.1.

Return to Section TOC

Return to Section TOC

Return to Section TOC

Return to Section TOC

Return to Master TOC

Return to Master TOC

Return to Master TOC

Return to Master TOC

FIGURE E.2 — INPUT RECEPTACLE, CONTROL BOARD AND OPERATOR CONTROLS.

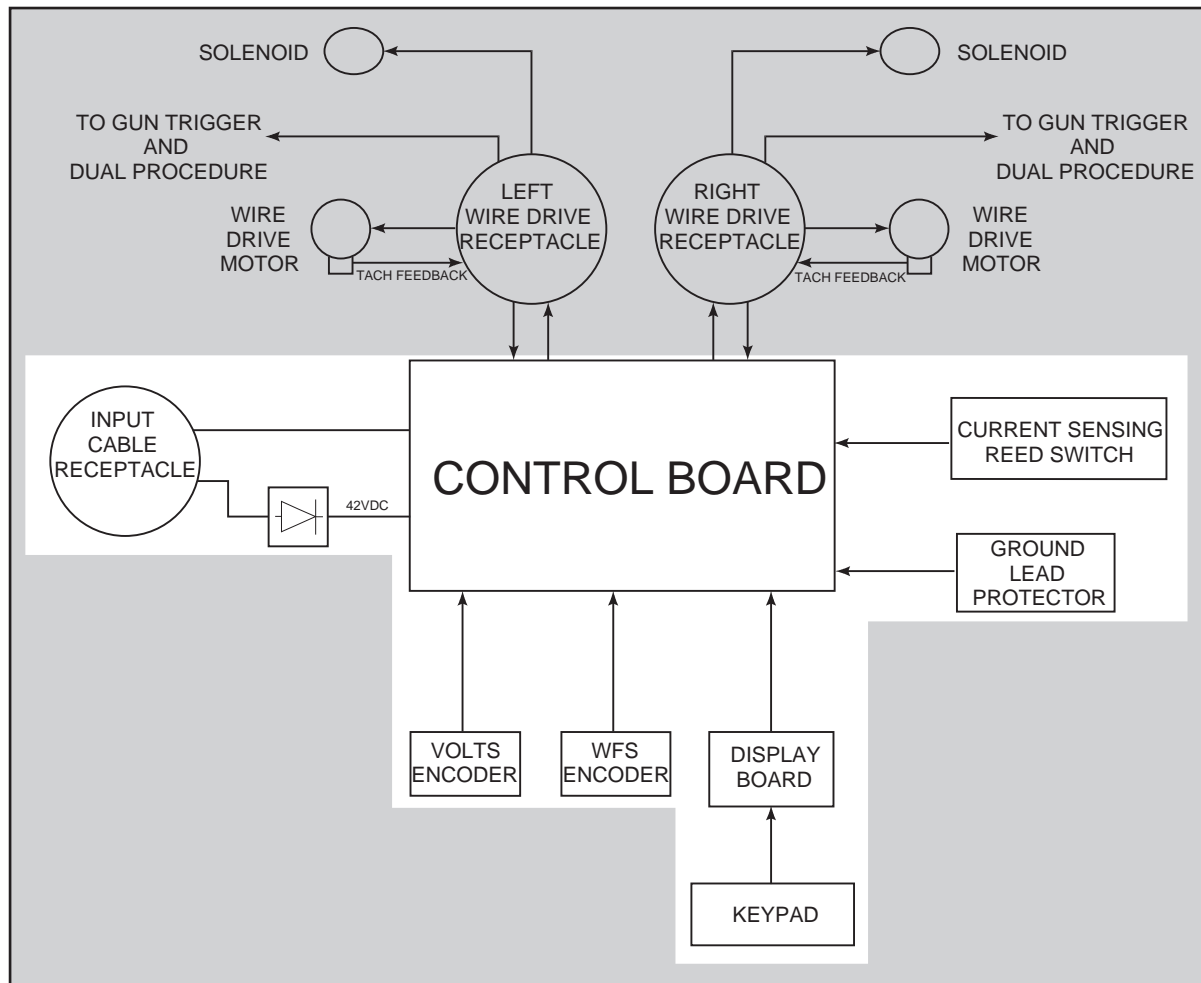

INPUT RECEPTACLE, CONTROL BOARD, AND OPERATOR CONTROLS

The 42 VAC input voltage is applied to the DH-10 through a 9-pin amphenol type receptacle. The remote control and trigger leads are also accessed through this 9-pin receptacle. The 42 VAC is rectified by a full wave bridge and sent to the control board. This DC voltage is coupled to an onboard switching power supply. The switching power supply manufactures regulated ± 12.8 VDC and +5.0 VDC regulated supplies for the control board. Refer to Figure E.2.

The control board receives commands from the user operated controls such as the volts encoder, the wire

feed speed (WFS) encoder, and the keypad. It also receives feedback information from the active wire feed head as to the wire feed speed and the arc voltage. The control board compares the feedback information with the user command signals and generates the appropriate signals to control wire feed speed, arc voltage, and gas flow.

The current sensing switch and ground lead protector are connected to the control board via plug J1. The current sensing reed switch closes when welding current is established which signals the control board to change from the run-in welding parameters to the preset welding wire feed speed and arc voltage. If the ground lead protector is activated, the trigger circuit will be disabled and the WFS display will show "GLP".

FIGURE E.3 — WIRE FEED HEADS AND RECEPTACLES.

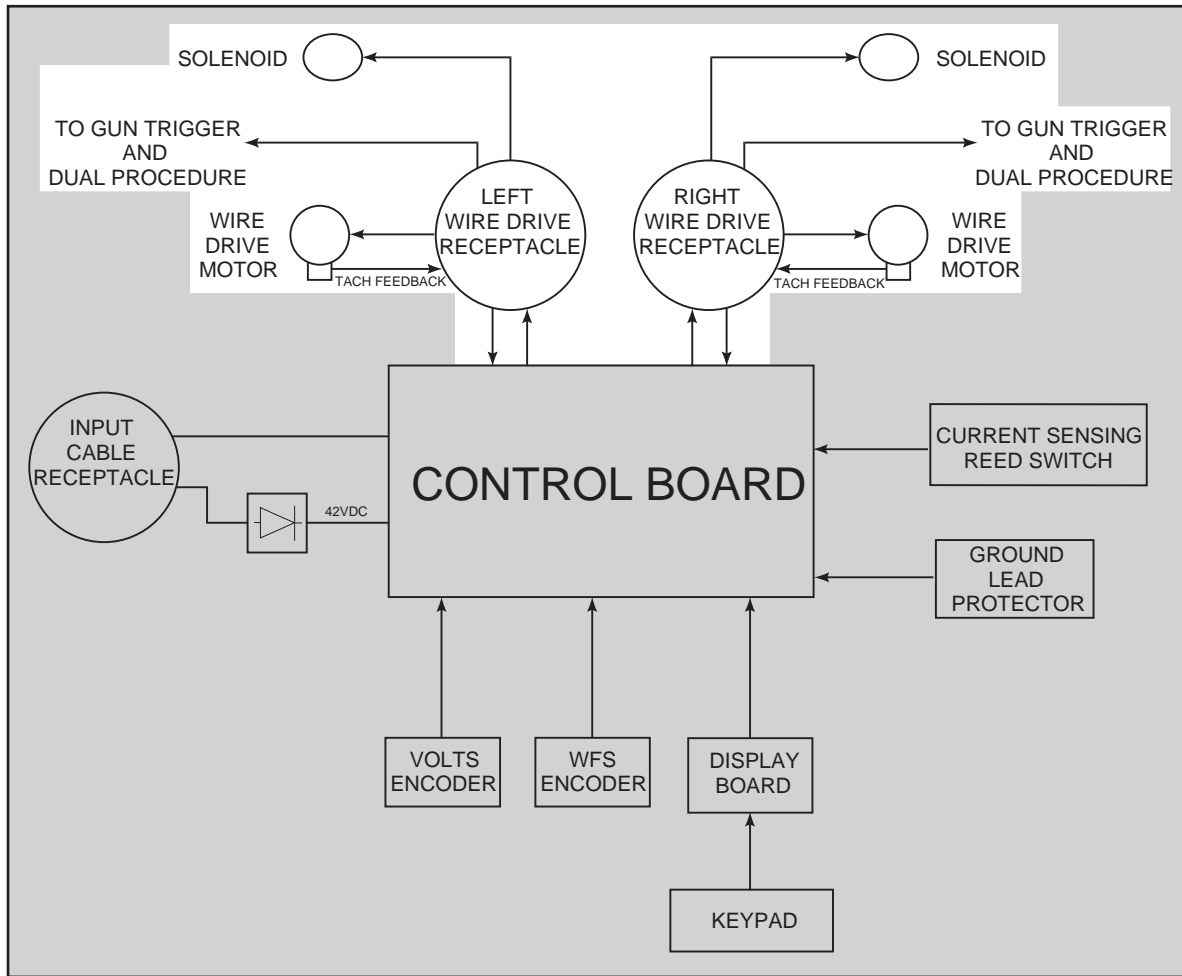

WIRE FEED HEADS AND RECEPTACLES

The leads to the drive motor, gas solenoid, and the tach (hall effect device) are brought into the control box via the wire drive receptacles. These two 14-pin receptacles also house the gun trigger leads, the electrode voltage sense lead, and the leads for the optional remote with dual procedure capability. Refer to Figure E.3.

When the gun trigger is activated, the control board energizes the gas solenoid, then the welding drive motor and welding power source. The control board receives tach feedback information and adjusts the motor armature voltage to match the preset wire feed speed.

TABLE OF CONTENTS

-TROUBLESHOOTING AND REPAIR SECTION-

Troubleshooting and Repair	Section F
How to Use Troubleshooting Guide	F-2
PC Board Troubleshooting Procedures	F-3
Troubleshooting Guide	F-5
Test Procedures	F-17
Wire Drive Motor Test	F-17
Tach Adjustment and Feedback Test	F-19
Keypad Resistance Test	F-23
Encoder PC Board Test	F-27
Gas Solenoid Test	F-29
Component Replacement Procedures	F-31
Display PC Board Removal and Replacement	F-31
Gas Solenoid Removal and Replacement	F-33
Encoder PC Board Removal and Replacement	F-35
Wire Drive Motor and Gear Box Removal and Replacement	F-37
Retest After Repair	F-41

HOW TO USE TROUBLESHOOTING GUIDE

⚠ WARNING

Service and Repair should only be performed by Lincoln Electric Factory Trained Personnel. Unauthorized repairs performed on this equipment may result in danger to the technician and machine operator and will invalidate your factory warranty. For your safety and to avoid electrical shock, please observe all safety notes and precautions detailed throughout this manual.

This Troubleshooting Guide is provided to help you locate and repair possible machine malfunctions. Simply follow the three-step procedure listed below.

Step 1. LOCATE PROBLEM (SYMPTOM).

Look under the column labeled "PROBLEM (SYMPTOMS)". This column describes possible symptoms that the machine may exhibit. Find the listing that best describes the symptom that the machine is exhibiting. Symptoms are grouped into the following categories: function problems, feeding problems, and welding problems.

Step 2. PERFORM EXTERNAL TESTS.

The second column labeled "POSSIBLE AREAS OF MISADJUSTMENT(S)" lists the obvious external possibilities that may contribute to the machine symptom. Perform these tests/checks in the order listed. In general, these tests can be conducted without removing the case wrap-around cover.

Step 3. RECOMMENDED COURSE OF ACTION.

The last column labeled "RECOMMENDED COURSE OF ACTION" lists the most likely components that may have failed in your machine. It also specifies the appropriate test procedure to verify that the subject component is either good or bad. If there are a number of possible components, check the components in the order listed to eliminate one possibility at a time until you locate the cause of your problem.

All of the referenced test procedures referred to in the Troubleshooting Guide are described in detail at the end of this chapter. Refer to the Troubleshooting and Repair Table of Contents to locate each specific Test Procedure. All of the specified test points, components, terminal strips, etc. can be found on the referenced electrical wiring diagrams and schematics. Refer to the Electrical Diagrams Section Table of Contents to locate the appropriate diagram.

⚠ CAUTION

If for any reason you do not understand the test procedures or are unable to perform the tests/repairs safely, contact the Lincoln Electric Service Department for technical troubleshooting assistance before you proceed. Call 216-383-2531 or 1-800-833-9353.

PC BOARD TROUBLESHOOTING PROCEDURES

WARNING**ELECTRIC SHOCK
can kill.**

Have an electrician install and service this equipment. Turn the input power OFF at the fuse box before working on equipment. Do not touch electrically hot parts.

CAUTION

Sometimes machine failures appear to be due to PC board failures. These problems can sometimes be traced to poor electrical connections. To avoid problems when troubleshooting and replacing PC boards, please use the following procedure:

1. Determine to the best of your technical ability that the PC board is the most likely component causing the failure symptom.
2. Check for loose connections at the PC board to assure that the PC board is properly connected.
3. If the problem persists, replace the suspect PC board using standard practices to avoid static electrical damage and electrical shock. Read the warning inside the static resistant bag and perform the following procedures:



**ATTENTION
Static-Sensitive
Devices
Handle only at
Static-Safe
Workstations**

**Reusable
Container
Do Not Destroy**

PC board can be damaged by static electricity.

- Remove your body's static charge before opening the static-shielding bag. Wear an anti-static wrist strap. For safety, use a 1 Meg ohm resistive cord connected to a grounded part of the equipment frame.
- If you don't have a wrist strap, touch an unpainted, grounded, part of the equipment frame. Keep touching the frame to prevent static build-up. Be sure not to touch any electrically live parts at the same time.
- Tools which come in contact with the PC board must be either conductive, anti-static or static-dissipative.
- Remove the PC board from the static-shielding bag and place it directly into the equipment. Don't set the PC board on or near paper, plastic or cloth which could have a static charge. If the PC board cannot be installed immediately, put it back in the static-shielding bag.
- If the PC board uses protective shorting jumpers, don't remove them until installation is complete.
- If you return a PC board to the Lincoln Electric Company for credit, it must be in the static-shielding bag. This will prevent further damage and allow proper failure analysis.

4. Test the machine to determine if the failure symptom has been corrected by the replacement PC board.

NOTE: It is desirable to have a spare (known good) PC board available for PC board troubleshooting.

NOTE: Allow the machine to heat up so that all electrical components can reach their operating temperature.

5. Remove the replacement PC board and substitute it with the original PC board to recreate the original problem.

- a. If the original problem does not reappear by substituting the original board, then the PC board was not the problem. Continue to look for bad

connections in the control wiring harness, junction blocks, and terminal strips.

- b. If the original problem is recreated by the substitution of the original board, then the PC board was the problem. Reinstall the replacement PC board and test the machine.

6. Always indicate that this procedure was followed when warranty reports are to be submitted.

NOTE: Following this procedure and writing on the warranty report, "INSTALLED AND SWITCHED PC BOARDS TO VERIFY PROBLEM," will help avoid denial of legitimate PC board warranty claims.

TROUBLESHOOTING GUIDE

Observe all Safety Guidelines detailed throughout this manual.

PROBLEMS (SYMPTOMS)	POSSIBLE AREAS OF MISADJUSTMENT(S)	RECOMMENDED COURSE OF ACTION
FUNCTION PROBLEMS		
Neither drive motor turns when the gun triggers are activated. The displays are lit and the correct input voltage (42 VAC) is applied to the DH-10.	<ol style="list-style-type: none"> 1. If an error message "HXX" appears on the wire feed display, the unit may be overloaded. The "XX" indicates the time remaining in seconds before the unit automatically resets. 2. Make certain the dip switches are set correctly for the power source being used. See Welding Power Source Selection. 3. If the control board is a G3041-2 or later, a jumper plug or a K1558-1 remote switch interface module must be installed into connector J5 on the control board. 	<ol style="list-style-type: none"> 1. For feeders using the Remote Switch Interface Module, make sure there is continuity (zero ohms) in the circuit connecting the two terminals marked 1A on the remote switch interface P.C. board. Also check that there is continuity in the circuit connecting the two terminals marked 2A. 2. Make sure the gun trigger circuits are working properly. See the Wiring Diagram. 3. Perform the Wire Drive Motor Test. 4. The control board may be faulty.
One side's drive motor does not turn, although the arc voltage is present and the gas solenoid works and the gun trigger is activated.	<ol style="list-style-type: none"> 1. Check the connections between the drive motor and the control board. See the Wiring Diagram. 	<ol style="list-style-type: none"> 1. Perform the Wire Drive Motor Test. 2. The control board may be faulty.
There is NO control of wire feed speed on one side only. Both motors turn, both gas solenoids operate and arc voltage is present. The WFS can be preset.	<ol style="list-style-type: none"> 1. Check the tach leads between the tach (hall effect device) and the control board. See the Wiring Diagram. 	<ol style="list-style-type: none"> 1. Perform the Tach Adjustment and Feedback Test. 2. Perform the Wire Drive Motor Test.

 **CAUTION**

If for any reason you do not understand the test procedures or are unable to perform the tests/repairs safely, contact the Lincoln Electric Service Department for technical troubleshooting assistance before you proceed. Call 216-383-2531 or 1-800-833-9353.

Observe all Safety Guidelines detailed throughout this manual.

PROBLEMS (SYMPTOMS)	POSSIBLE AREAS OF MISADJUSTMENT(S)	RECOMMENDED COURSE OF ACTION
FUNCTION PROBLEMS (Continued)		
<p>No control of wire feed speed on both sides. Both motors run, both solenoids operate and arc voltage is present. The WFS can be preset on both sides.</p>	<ol style="list-style-type: none"> 1. Check the tach leads between the tach (hall effect devices) and the control board. See the Wiring Diagram. 	<ol style="list-style-type: none"> 1. Perform the <i>Tach Adjustment and Feedback Test</i>. 2. Perform the <i>wire Drive Motor Test</i>. 3. The control board may be defective.
<p>The wire feeds and the gas solenoid operates but no arc voltage is present.</p>	<ol style="list-style-type: none"> 1. Make certain the electrode and work cables are connected correctly. 2. Make certain the control cable between the DH- 10 and the power source is in good working condition. 3. Make certain the power source is operating properly and capable of producing welding voltage and current. 	<ol style="list-style-type: none"> 1. Check the continuity (zero ohms) of leads #2 and #4 between the input cable receptacle and plug j8 on the control board. See the Wiring Diagram. 2. The control board may be faulty.

Return to Section TOC

Return to Section TOC

Return to Section TOC

Return to Section TOC

Return to Master TOC

Return to Master TOC

Return to Master TOC

Return to Master TOC

⚠ CAUTION

If for any reason you do not understand the test procedures or are unable to perform the tests/repairs safely, contact the Lincoln Electric Service Department for technical troubleshooting assistance before you proceed. Call 216-383-2531 or 1-800-833-9353.

Observe all Safety Guidelines detailed throughout this manual.

PROBLEMS (SYMPTOMS)	POSSIBLE AREAS OF MISADJUSTMENT(S)	RECOMMENDED COURSE OF ACTION
FUNCTION PROBLEMS (Continued)		
<p>The wire feed speed does not change when welding current is established.</p>	<ol style="list-style-type: none"> 1. The “run-in” and “weld” wire feed speeds may be set at the same value. 2. Check the current sensing reed switch leads and connectors for loose or faulty connections. See the Wiring Diagram. 	<ol style="list-style-type: none"> 1. Check the current sensing reed switch for proper operation. <ol style="list-style-type: none"> A. While not welding the voltage at pins 3J1 to 4J1 should be approximately 12 VDC. The reed switch should be open. If the 12 VDC is missing either the reed switch is stuck closed or the control board is defective. B. While welding current is flowing the voltage at pins 3J1 to 4J1 should be approximately 0 VDC. The reed switch should be closed. If the voltage is not at or near 0VDC, the reed switch is faulty. 2. The control board may be faulty.
<p>The voltmeter does not function properly. The welding may vary from normal performance. The wire feeds properly.</p>	<ol style="list-style-type: none"> 1. Make sure the dip switch settings on the control board are correct for the power source being used. See Welding Power Source Selection. 2. Make sure the voltage sense leads are connected. <ol style="list-style-type: none"> A. Lead #67 has continuity (zero ohms) to the electrode. B. Lead #21 has continuity (zero ohms) to the work piece. 	<ol style="list-style-type: none"> 1. The control board may be faulty. 2. The display board may be defective.

⚠ CAUTION

If for any reason you do not understand the test procedures or are unable to perform the tests/repairs safely, contact the Lincoln Electric Service Department for technical troubleshooting assistance before you proceed. Call 216-383-2531 or 1-800-833-9353.

Return to Section TOC

Return to Section TOC

Return to Section TOC

Return to Section TOC

Return to Master TOC

Return to Master TOC

Return to Master TOC

Return to Master TOC

Observe all Safety Guidelines detailed throughout this manual.

PROBLEMS (SYMPTOMS)	POSSIBLE AREAS OF MISADJUSTMENT(S)	RECOMMENDED COURSE OF ACTION
FUNCTION PROBLEMS (Continued)		
The "Cold Feed Forward" and/or the "Cold Feed Reverse" buttons do not function properly. Both motors operate properly in other modes.	<ol style="list-style-type: none"> 1. Check the connectors and wires between the display board and the control board for loose or faulty connections. (J11 and J3) 2. Check the connector J10 between the keypad and the display board for loose corrections. 	<ol style="list-style-type: none"> 1. Perform the Keypad Resistance Test. 2. The display board may be faulty. 3. The control board may be faulty.
The "Gas Purge" button does not activate the gas solenoid. The gas solenoid operates properly in other modes.	<ol style="list-style-type: none"> 1. Check the connectors and wires between the display board and the control board for loose or faulty connections. (J11 and J3) 2. Check the connector J10 between the keypad and the display board for loose connections. 	<ol style="list-style-type: none"> 1. Perform the Keypad Resistance Test. 2. The display board may be faulty. 3. The control board may be faulty.
The "Feeder" button does not function. The feeder head can be selected by pulling the appropriate gun trigger.	<ol style="list-style-type: none"> 1. Check the connectors and wires between the display board and the control board for loose or faulty connections. (J11 and J3) 2. Check the connector J10 between the keypad and the display board for loose connections. 	<ol style="list-style-type: none"> 1. Perform the Keypad Resistance Test. 2. The display board may be faulty. 3. The control board may be faulty.
The "Procedure" button does not function properly.	<ol style="list-style-type: none"> 1. Check the connectors and wires between the display board and the control board for loose or faulty connections. (J11 and J3) 2. Check the connector J10 between the keypad and the display board for loose connections. 	<ol style="list-style-type: none"> 1. Perform the Keypad Resistance Test. 2. The display board may be faulty. 3. The control board may be faulty.

⚠ CAUTION

If for any reason you do not understand the test procedures or are unable to perform the tests/repairs safely, contact the Lincoln Electric Service Department for technical troubleshooting assistance before you proceed. Call 216-383-2531 or 1-800-833-9353.

Observe all Safety Guidelines detailed throughout this manual.

PROBLEMS (SYMPTOMS)	POSSIBLE AREAS OF MISADJUSTMENT(S)	RECOMMENDED COURSE OF ACTION
FUNCTION PROBLEMS (Continued)		
The "Timer", "Control" and/or "Trigger" buttons do not function correctly.	<ol style="list-style-type: none"> 1. Make certain the DIP switches on the control board are not set for the security mode. DIP switch S1 position 5 and position 8 must be in the OFF position. 2. Check the connectors and wires between the display board and the control board for loose or faulty connections. (J11 and J3) 3. Check the connector J10 between the keypad and the display board for loose connections. 	<ol style="list-style-type: none"> 1. Perform the Keypad Resistance Test. 2. The display board may be faulty. 3. The control board may be faulty.
One of the encoder control knobs functions but the other one does not.	<ol style="list-style-type: none"> 1. The unit maybe in a mode that utilizes only one display. To check if this is the problem, make sure that both knobs change the display when both displays are showing a number and the high security mode is disabled. 2. Check the wiring and plug connections between the encoder boards and the control board. (Plug J2) See the Wiring Diagram. 	<ol style="list-style-type: none"> 1. Perform the Encoder Board Test. 2. The control board may be faulty.
Neither encoder control knob functions.	<ol style="list-style-type: none"> 1. Make sure the DIP switches on the control board are NOT set for the high security mode. The high security mode disables the encoder controls. See the Operation Section. 2. Check the wiring and plug connections between the encoder boards and the control board. (Plug J2) See the Wiring Diagram. 	<ol style="list-style-type: none"> 1. Perform the Encoder Board Test. 2. The control board may be faulty.

CAUTION

If for any reason you do not understand the test procedures or are unable to perform the tests/repairs safely, contact the Lincoln Electric Service Department for technical troubleshooting assistance before you proceed. Call 216-383-2531 or 1-800-833-9353.

Observe all Safety Guidelines detailed throughout this manual.

PROBLEMS (SYMPTOMS)	POSSIBLE AREAS OF MISADJUSTMENT(S)	RECOMMENDED COURSE OF ACTION
FUNCTION PROBLEMS (Continued)		
The DH-10 is dead. The displays and LEDs on the keypad are off. The green and red LEDs on the control board are not lit.	<ol style="list-style-type: none"> 1. Make sure the DH-10 is connected properly to the power source. 2. Make sure 42 VAC is being applied to the DH-10 at the input receptacle terminals A and B. 	<ol style="list-style-type: none"> 1. The input rectifier bridge may be faulty. Check for 42 VAC at the red leads. Also check for at least 42 VDC at leads #542(+) to #500(-). See the Wiring Diagram. 2. The control board may be faulty.
The displays and LEDs on the keypad are off. The green and red LEDs on the control board are both blinking normally at about one second intervals.	<ol style="list-style-type: none"> 1. Check the wires and connectors (J11 and J3) between the display board and the control board for loose or faulty connections. 	<ol style="list-style-type: none"> 1. Check leads #512 (1J3) to #500 (3J3) for the presence of 12.8 VDC. If the 12.8 VDC is not present the control board may be faulty. 2. If the 12.8 VDC is present the display board may be faulty.
The displays and LEDs on the keypad are off. The green and/or red LEDs on the control board are blinking at a very fast or erratic rate.	<ol style="list-style-type: none"> 1. Make sure the DH-10 is connected properly to the power source. 2. Make sure 42 VAC is being applied to the DH-10 at the input receptacle terminals A and B. 	<ol style="list-style-type: none"> 1. The control board may be defective.
The wire feed is consistent and adjustable, but operates at the wrong speed.	<ol style="list-style-type: none"> 1. Make certain the DIP switch S1 is correctly set for the wire drive and gear ratio. See Wire Drive Head Selection. 	<ol style="list-style-type: none"> 1. The control board may be faulty.

 **CAUTION**

If for any reason you do not understand the test procedures or are unable to perform the tests/repairs safely, contact the Lincoln Electric Service Department for technical troubleshooting assistance before you proceed. Call 216-383-2531 or 1-800-833-9353.

Observe all Safety Guidelines detailed throughout this manual.

PROBLEMS (SYMPTOMS)	POSSIBLE AREAS OF MISADJUSTMENT(S)	RECOMMENDED COURSE OF ACTION
FUNCTION PROBLEMS (Continued)		
The wire feeds for a few seconds and stops. The voltage display reads less than 8 VDC while the wire is feeding.	<ol style="list-style-type: none"> 1. Make sure the electrode and work cables are connected securely and properly. 2. Make sure the #21 lead is connected correctly at the power source. 3. Make sure the power source is operating correctly and capable of putting out more than 8 VDC. 	<ol style="list-style-type: none"> 1. Make sure the #21 lead has continuity (zero ohms) to the workpiece and #67 lead has continuity (zero ohms) to the electrode wire. See the Wiring Diagram. 2. The control board may be faulty.
The dual procedure switch is not functioning at the gun on either side of the DH-10.	<ol style="list-style-type: none"> 1. Make sure the dual procedure switch is installed and connected properly. 2. The "Remote LED" on the keypad must be lit and the toggle switch on the remote control (if used) must be in the gun position. 	<ol style="list-style-type: none"> 1. The control board may be faulty.
The dual procedure switch functions properly when attached to one side of the DH-10 but will not operate on the other side.	<ol style="list-style-type: none"> 1. Check the connections and wiring between the dual procedure switch and the gun trigger connector. 2. Check the connections and wiring between the wire drive unit and the control box. Check leads #519 and #520 through the shielded cable to the control board. See the Wiring Diagram. 	<ol style="list-style-type: none"> 1. The control board may be faulty.

⚠ CAUTION

If for any reason you do not understand the test procedures or are unable to perform the tests/repairs safely, contact the Lincoln Electric Service Department for technical troubleshooting assistance before you proceed. Call 216-383-2531 or 1-800-833-9353.

Observe all Safety Guidelines detailed throughout this manual.

PROBLEMS (SYMPTOMS)	POSSIBLE AREAS OF MISADJUSTMENT(S)	RECOMMENDED COURSE OF ACTION
FUNCTION PROBLEMS (Continued)		
An "Er" message is displayed when the DH-10 is powered up.	1. This indicates an EEPROM error has been detected. Press any key to return to normal operation. Check all the settings to make sure they are within the acceptable ranges. If the "Er" message is still displayed remove the input power. While pressing the Timer and Control keys, turn on the input power. The message "Ln" should be displayed. Leave on for 5 seconds. Remove the input power. Note: All the settings will be removed.	1. The control board may be faulty.
A "GLP" message is displayed.	1. The Ground Lead Protector circuit has activated due to excessive current flow in the wire feeder frame. This can be caused by the electrode coming in contact with the wire feeder frame or poor connections in the work cable circuit. The wire feeder will be disabled. Remedy the "grounding" problem and resume normal operations by releasing the gun trigger and then closing the gun trigger.	1. The GLP reed switch may be faulty. This switch is normally open and should only close when current is flowing through the green lead and wire feeder frame. It may be stuck closed. See the Wiring Diagram. 2. The control board may be faulty.
When the gun trigger is activated the wire feeds and arc voltage is present but gas does not flow.	1. Make sure the gas supply is adequate and connected correctly to the DH-10.	1. Perform the Gas Solenoid Test . 2. The control board may be faulty.

 **CAUTION**

If for any reason you do not understand the test procedures or are unable to perform the tests/repairs safely, contact the Lincoln Electric Service Department for technical troubleshooting assistance before you proceed. Call 216-383-2531 or 1-800-833-9353.

Observe all Safety Guidelines detailed throughout this manual.

PROBLEMS (SYMPTOMS)	POSSIBLE AREAS OF MISADJUSTMENT(S)	RECOMMENDED COURSE OF ACTION
FUNCTION PROBLEMS (Continued)		
The preset arc voltage does not match the actual voltage.	<ol style="list-style-type: none"> 1. Make sure the power source is set for remote voltage control. 2. Make sure the DIP switches on the DH-10 control board are set correctly for the power source being used. 	<ol style="list-style-type: none"> 1. The control board may be faulty. 2. The control cable between the power source and the DH-10 may be defective.
The preset WFS does not match the actual WFS.	<ol style="list-style-type: none"> 1. Check the wiring and connections between the tachometer and the control board. See the Wiring Diagram. 2. Make sure the DIP switches on the DH-10 control board are set correctly. 3. The control board may be faulty. 	<ol style="list-style-type: none"> 1. Perform the <i>Tach Adjustment and Feedback Test.</i>

 **CAUTION**

If for any reason you do not understand the test procedures or are unable to perform the tests/repairs safely, contact the Lincoln Electric Service Department for technical troubleshooting assistance before you proceed. Call 216-383-2531 or 1-800-833-9353.

Observe all Safety Guidelines detailed throughout this manual.

PROBLEMS (SYMPTOMS)	POSSIBLE AREAS OF MISADJUSTMENT(S)	RECOMMENDED COURSE OF ACTION
FEEDING PROBLEMS		
<p>The wire is feeding rough or not feeding, but the drive rolls are turning.</p>	<ol style="list-style-type: none"> 1. Check for mechanical restrictions in the wire feed path. 2. Make sure the gun liner is correct for the electrode wire being used. 3. Check the contact tip. 4. Make sure the drive rolls are installed correctly. 5. Make sure the DIP switches on the control board are set correctly 	<ol style="list-style-type: none"> 1. If the drive rolls are turning erratically perform the wire Drive Motor Test and Tach Adjustment and Feedback Test.
<p>The contact tip seizes in the gun liner.</p>	<ol style="list-style-type: none"> 1. The tip may be overheated because of prolonged or excessive high current and/or duty cycle. 	<ol style="list-style-type: none"> 1. Apply a light coating of high temperature anti-seize lubricant (such as Lincoln Electric E2067 graphite grease) to the tip's threads.

 **CAUTION**

If for any reason you do not understand the test procedures or are unable to perform the tests/repairs safely, contact the Lincoln Electric Service Department for technical troubleshooting assistance before you proceed. Call 216-383-2531 or 1-800-833-9353.

Observe all Safety Guidelines detailed throughout this manual.

PROBLEMS (SYMPTOMS)	POSSIBLE AREAS OF MISADJUSTMENT(S)	RECOMMENDED COURSE OF ACTION
WELDING PROBLEMS		
The welding arc is variable or "hunting".	<ol style="list-style-type: none"> 1. The electrode or work cables may have faulty connections. 2. Make sure the welding procedures are correct for the process being used. 3. Make sure the DIP switches on the control board are set correctly. 4. The gas shielding may not be sufficient or contaminated. 5. The power source may be faulty. 	<ol style="list-style-type: none"> 1. If the drive rolls are turning erratically perform the wire Drive Motor Test and Tach Adjustment and Feedback Test.
Poor arc striking with sticking or "blast-offs". The bead may be narrow, ropey and have porosity.	<ol style="list-style-type: none"> 1. Make sure the welding procedures are correct for the process being used. 2. The gas shielding may not be sufficient or contaminated. 3. Make sure the set screw in the connector block is in place and tightened against the liner bushing. 4. Weld procedures and/or parameters incorrect for process being performed. 5. The power source may be faulty. 	<ol style="list-style-type: none"> 1. If the drive rolls are turning erratically perform the wire Drive Motor Test and Tach Adjustment and Feedback Test. 2. Make certain weld procedures and parameters are correct for the process being performed.

 **CAUTION**

If for any reason you do not understand the test procedures or are unable to perform the tests/repairs safely, contact the Lincoln Electric Service Department for technical troubleshooting assistance before you proceed. Call 216-383-2531 or 1-800-833-9353.

Return to Section TOC

Return to Section TOC

Return to Section TOC

Return to Section TOC

Return to Master TOC

Return to Master TOC

Return to Master TOC

TEST PROCEDURES

WIRE DRIVE MOTOR TEST

WARNING

Service and repair should only be performed by Lincoln Electric factory trained personnel. Unauthorized repairs performed on this equipment may result in danger to the technician or machine operator and will invalidate your factory warranty. For your safety and to avoid electrical shock, please observe all safety notes and precautions detailed throughout this manual.

If for any reason you do not understand the test procedures or are unable to perform the test/repairs safely, contact the Lincoln Electric service department for technical troubleshooting assistance before you proceed. Call 216-383-2531 or 1-800-833-9353(WELD).

TEST DESCRIPTION

This test will help determine if the wire drive motor is receiving the correct voltage and is capable of running properly. Either motor can be checked with this procedure.

MATERIALS NEEDED

5/16 in. nutdriver
Volt-Ohmmeter

Return to Section TOC

Return to Section TOC

Return to Section TOC

Return to Section TOC

Return to Master TOC

Return to Master TOC

Return to Master TOC

Return to Master TOC

DH-10

 LINCOLN[®]
ELECTRIC

WIRE DRIVE MOTOR TEST (continued)

FIGURE F.1 — WIRE DRIVE MOTOR TEST.

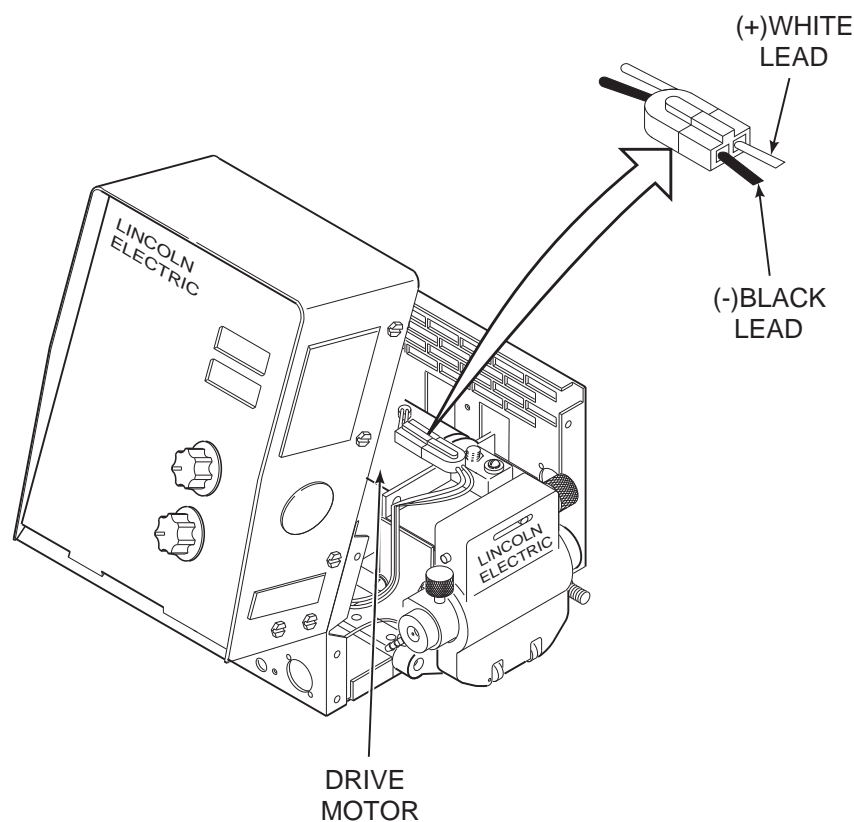

TEST PROCEDURE

1. Remove input power to the DH-10 unit.
2. Using the 5/16 in. nutdriver, remove the wire drive cover.
3. Locate the motor armature leads for the motor to be tested (one black (-) lead and one white (+) lead). Do not disconnect the leads. See Figure F.1.
4. Apply the correct input power (42 VAC) to the DH-10. Activate the gun trigger. With the motor running, check the armature voltage at the black (-) and white (+) leads. The normal voltage range is approximately 1 to 25 VDC depending on motor speed. When the armature voltage is increased the motor speed should also increase.
5. If the correct voltages are NOT present at the armature motor leads, check the associated leads and plugs for loose or faulty connections. See the Wiring Diagram. If the leads and connections are OK, the control board may be faulty.
6. If the correct voltages are present at the motor armature leads and the motor does not run and vary speed with changes in armature voltage, the motor or gear box may be faulty. See **Wire Drive Motor** and **Gear Box Removal and Replacement**.
7. Install the wire drive cover.

TACH ADJUSTMENT AND FEEDBACK TEST

 **WARNING**

Service and repair should only be performed by Lincoln Electric factory trained personnel. Unauthorized repairs performed on this equipment may result in danger to the technician or machine operator and will invalidate your factory warranty. For your safety and to avoid electrical shock, please observe all safety notes and precautions detailed throughout this manual.

If for any reason you do not understand the test procedures or are unable to perform the test/repairs safely, contact the Lincoln Electric service department for technical troubleshooting assistance before you proceed. Call 216-383-2531 or 1-800-833-9353(WELD).

TEST DESCRIPTION

This test will determine if the hall effect module (tach) is functioning correctly. Either tach can be checked using this procedure.

MATERIALS NEEDED

5/16 in. nutdriver
Volt-Ohmmeter
9/16 in. wrench

Return to Section TOC

Return to Master TOC

Return to Section TOC

Return to Master TOC

Return to Section TOC

Return to Master TOC

Return to Section TOC

Return to Master TOC

DH-10

 **LINCOLN**[®]
ELECTRIC

TACH ADJUSTMENT AND FEEDBACK TEST (*continued*)

FIGURE F.2 — TACH FEEDBACK TEST.

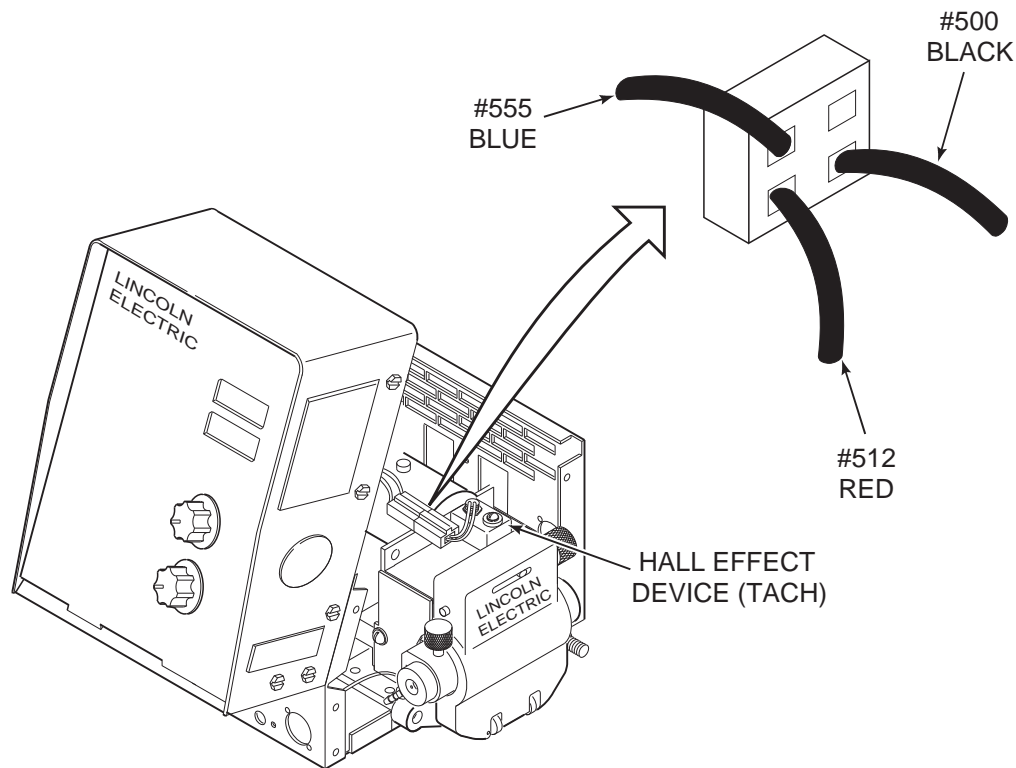
**TEST PROCEDURE**

1. Remove input power to the DH-10 unit.
2. Using the 5/16 in. nutdriver, remove the wire drive cover.
3. Locate the three hall effect leads (blue, red and black). See Figure F.2.
4. Apply the correct input power (42 VAC) to the DH-10.
5. Check for approximately 12 VDC from red lead #512 (+) to black lead #500 (-). If the 12 VDC is NOT present or low, the control board or associated leads or plugs may be faulty. See the Wiring Diagram.
6. Activate the gun trigger. Make sure the motor is running. Check for the presence of approximately 5.0 VDC from blue lead #555 (+) to black lead #500 (-). The 5.0 VDC represents the correct feedback voltage from the hall effect device to the control board.
7. If the above voltage reading is not correct, the hall effect device may need to be adjusted or replaced. See **Tach Adjustment Procedure**.

TACH ADJUSTMENT AND FEEDBACK TEST *(continued)***TACH ADJUSTMENT
PROCEDURE**

Proper positioning of the module is critical to the proper operation the DH-10 wire feeder. If the device is not screwed in far enough the motor speed could be unstable or run at full speed with no control. If screwed in too far it will rub a moving part inside the gearbox.

1. Remove input power to the DH-10 wire feeder.
2. Make sure the module is securely attached to the gearbox.

3. Using the 9/16 in. wrench loosen the locking nut.
4. Gently screw the hall effect module into the mounting plate until it just touches and stops against the rotating part inside the gearbox. See Figure F.2.
5. Back the module out 1/2 turn. Using the 9/16 in. wrench and carefully snug the locknut without rotating the module position.
6. Install the wire drive cover.

Return to Section TOC

Return to Master TOC

Return to Section TOC

Return to Master TOC

Return to Section TOC

Return to Master TOC

Return to Section TOC

Return to Master TOC

[Return to Section TOC](#)

[Return to Section TOC](#)

[Return to Section TOC](#)

[Return to Section TOC](#)

[Return to Master TOC](#)

[Return to Master TOC](#)

[Return to Master TOC](#)

[Return to Master TOC](#)

F-22

NOTES

F-22



DH-10

KEYPAD RESISTANCE TEST

 **WARNING**

Service and repair should only be performed by Lincoln Electric factory trained personnel. Unauthorized repairs performed on this equipment may result in danger to the technician or machine operator and will invalidate your factory warranty. For your safety and to avoid electrical shock, please observe all safety notes and precautions detailed throughout this manual.

If for any reason you do not understand the test procedures or are unable to perform the test/repairs safely, contact the Lincoln Electric service department for technical troubleshooting assistance before you proceed. Call 216-383-2531 or 1-800-833-9353(WELD).

TEST DESCRIPTION

This test will determine if any key is not functioning properly.

MATERIALS NEEDED

5/16 in. nutdriver
Analog Volt-Ohmmeter
Small screwdriver

Return to Section TOC

Return to Master TOC

Return to Section TOC

Return to Master TOC

Return to Section TOC

Return to Master TOC

Return to Section TOC

Return to Master TOC

DH-10



KEYPAD RESISTANCE TEST (continued)

FIGURE F.3 — KEYPAD RESISTANCE TEST.

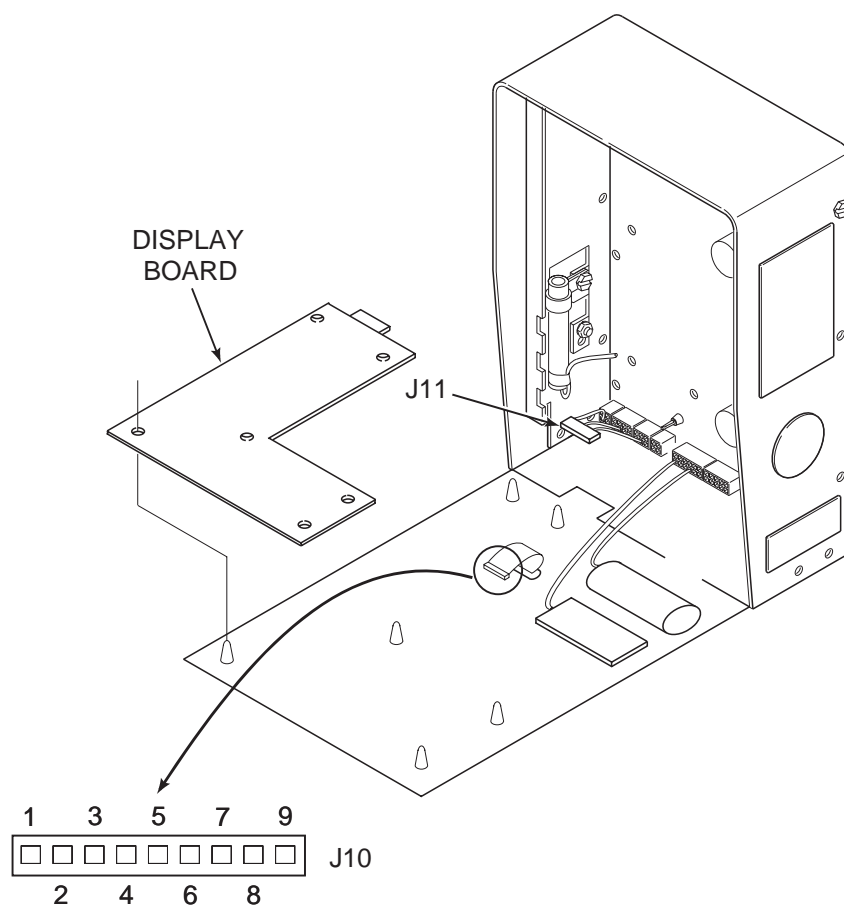

TEST PROCEDURE

1. Remove input power to the DH-10 unit.
2. Using the 5/16 in. nutdriver, remove the two screws from the top of the control panel. See Figure F.3.
3. Carefully lower the control panel.
4. Remove plug J11 from the display board.
5. Perform the *Display Board Removal Procedure*.
6. Check the keypad resistances referencing Figure F.3 and **Table F.1**.
7. The resistances are checked at plug J10 on the keypad. See Figure F.3.
8. If any of the resistances are not correct, the keypad may be faulty.
9. When test is complete, carefully install the display board and connect plugs J10 and J11.
10. Reassemble the front panel.

KEYPAD RESISTANCE TEST (continued)

NOTE: There should not be continuity between pins until a key is pressed on the keypad.

TABLE F.1 — KEYPAD RESISTANCE TEST.

TEST POINTS		KEY PRESSED	MAXIMUM ALLOWABLE RESISTANCE (TYPICAL RESISTANCE)
FROM PIN	TO PIN		
1J10	2J10	CONTROL	100 OHMS (50 OHMS TYPICAL)
1J10	3J10	TIMER	100 OHMS (50 OHMS TYPICAL)
1J10	4J10	TRIGGER	100 OHMS (50 OHMS TYPICAL)
1J10	5J10	FEEDER	100 OHMS (50 OHMS TYPICAL)
1J10	6J10	PROCEDURE	100 OHMS (50 OHMS TYPICAL)
1J10	7J10	COLD FEED FORWARD	100 OHMS (50 OHMS TYPICAL)
1J10	8J10	COLD FEED REVERSE	100 OHMS (50 OHMS TYPICAL)
1J10	9J10	GAS PURGE	100 OHMS (50 OHMS TYPICAL)

Return to Section TOC
Return to Master TOCReturn to Section TOC
Return to Master TOCReturn to Section TOC
Return to Master TOCReturn to Section TOC
Return to Master TOC

[Return to Section TOC](#)

[Return to Section TOC](#)

[Return to Section TOC](#)

[Return to Section TOC](#)

[Return to Master TOC](#)

[Return to Master TOC](#)

[Return to Master TOC](#)

[Return to Master TOC](#)



ENCODER PC BOARD TEST

 **WARNING**

Service and repair should only be performed by Lincoln Electric factory trained personnel. Unauthorized repairs performed on this equipment may result in danger to the technician or machine operator and will invalidate your factory warranty. For your safety and to avoid electrical shock, please observe all safety notes and precautions detailed throughout this manual.

If for any reason you do not understand the test procedures or are unable to perform the test/repairs safely, contact the Lincoln Electric service department for technical troubleshooting assistance before you proceed. Call 216-383-2531 or 1-800-833-9353(WELD).

TEST DESCRIPTION

This test will help determine if the encoder PC boards are functioning properly.

MATERIALS NEEDED

5/16 in. nutdriver
Volt-Ohmmeter (analog recommended)

Return to Section TOC

Return to Master TOC

Return to Section TOC

Return to Master TOC

Return to Section TOC

Return to Master TOC

Return to Section TOC

Return to Master TOC

DH-10



ENCODER PC BOARD TEST (continued)

FIGURE F.4 — ENCODER PC BOARD TEST.

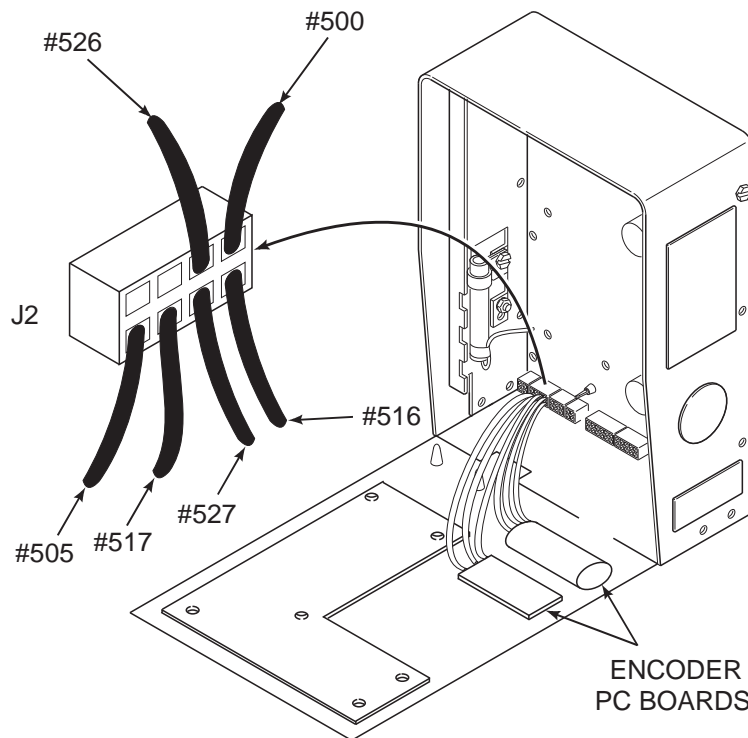

TEST PROCEDURE

1. Remove input power to the DH-10 unit.
 2. Using the 5/16 in. nutdriver, remove the two screws from the top of the control panel.
 3. Carefully lower the control panel.
 4. Locate plug J2 on the control board. See Figure F.4. Do not remove the plug from the control board.
 5. Apply the correct input power (42 VAC) to the DH-10 unit.
 6. Carefully check for the presence of 5 VDC from 5J2 (lead #505) to 4J2 (lead #500). This is the supply voltage from the control board to both encoder boards. (Volts and WFS). If this voltage is missing or low the control board may be defective. Also make certain the 5 VDC supply is being applied to the encoder boards via leads #505 and #500. See the Wiring Diagram.
 7. While slowly rotating the Volts control check for a “pulsing” 0 to 5 VDC signal from 8J2 (lead #516) to 6J2 (lead #517). If the 5 VDC supply IS present at the encoder board and the pulsing signal is NOT, the Volts encoder board may be faulty. Also check the lead and plug connections between the encoder board and the control board. See the Wiring Diagram.
 8. While slowly rotating the WFS control check for a “pulsing” 0 to 5 VDC signal from 3J2 (lead #526) to 7J2 (lead #527). If the 5 VDC supply IS present at the encoder board and the pulsing signal is NOT, the WFS encoder board may be faulty. Also check the lead and plug connections between the encoder board and the control board. See the Wiring Diagram.
- NOTE:** “Pulsing” means that as the control is rotated the signal will fluctuate from 0 to 5 VDC.
9. Remove input power to the DH-10 unit.
 10. Reassemble the control panel.

GAS SOLENOID TEST

 **WARNING**

Service and repair should only be performed by Lincoln Electric factory trained personnel. Unauthorized repairs performed on this equipment may result in danger to the technician or machine operator and will invalidate your factory warranty. For your safety and to avoid electrical shock, please observe all safety notes and precautions detailed throughout this manual.

If for any reason you do not understand the test procedures or are unable to perform the test/repairs safely, contact the Lincoln Electric service department for technical troubleshooting assistance before you proceed. Call 216-383-2531 or 1-800-833-9353(WELD).

TEST DESCRIPTION

This procedure will help determine if the gas solenoids are receiving the correct voltages and if the solenoids are functional. This test can be used for either gas solenoid.

MATERIALS NEEDED

5/16 in. nutdriver
Volt-Ohmmeter
12 VDC @ 1 amp power source

Return to Section TOC

Return to Master TOC

Return to Section TOC

Return to Master TOC

Return to Section TOC

Return to Master TOC

Return to Section TOC

Return to Master TOC

DH-10

 LINCOLN[®]
ELECTRIC

GAS SOLENOID TEST (continued)

FIGURE F.5 — GAS SOLENOID TEST.

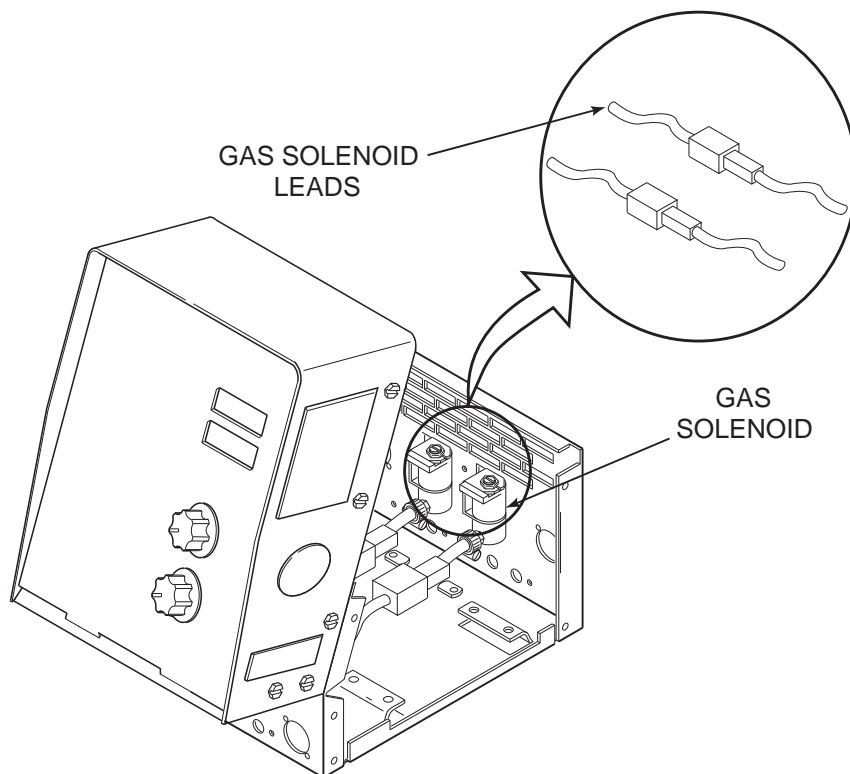

NOTE: WIRE FEEDER SHOWN WITH DRIVE MOTOR ASSEMBLY REMOVED FOR CLARITY

TEST PROCEDURE

1. Remove input power to the DH-10 unit.
2. Using the 5/16 in. nutdriver, remove the wire drive cover.
3. Locate the gas solenoids and lead quick connects. See Figure F.5. Do not disconnect the leads.
4. Apply the correct input power (42 VAC) to the DH-10 unit.
5. While pressing the gas purge button or activating the appropriate gun trigger, check for approximately 10 VDC at the solenoid leads. If the 10 VDC is present the gas solenoid should activate.
6. If the 10 VDC is missing or low, check the leads and connections between the solenoid and the control board. See the Wiring Diagram. If the leads and connections are OK the control board may be faulty.
7. If the 10 VDC is present at the solenoid leads and the solenoid does not activate the solenoid may be faulty. Normal solenoid coil resistance is approximately 22 ohms.
8. The solenoid(s) can be further checked by disconnecting the solenoid leads from the DH-10 wiring harness and applying an external 12 VDC supply to the leads. If the solenoid does not activate the solenoid is faulty.
9. Reconnect all disconnected leads.
10. Install the wire drive cover.

COMPONENT REPLACEMENT PROCEDURES**DISPLAY PC BOARD REMOVAL AND REPLACEMENT****⚠ WARNING**

Service and repair should only be performed by Lincoln Electric factory trained personnel. Unauthorized repairs performed on this equipment may result in danger to the technician or machine operator and will invalidate your factory warranty. For your safety and to avoid electrical shock, please observe all safety notes and precautions detailed throughout this manual.

If for any reason you do not understand the test procedures or are unable to perform the test/repairs safely, contact the Lincoln Electric service department for technical troubleshooting assistance before you proceed. Call 216-383-2531 or 1-800-833-9353(WELD).

DESCRIPTION

This will aid the technician in the removal and replacement of the display PC board.

MATERIALS NEEDED

5/16 in. nutdriver
Small screwdriver

Return to Section TOC
Return to Master TOCReturn to Section TOC
Return to Master TOCReturn to Section TOC
Return to Master TOCReturn to Section TOC
Return to Master TOC

DISPLAY PC BOARD REMOVAL AND REPLACEMENT *(continued)*

FIGURE F.6 — DISPLAY PC BOARD REMOVAL AND REPLACEMENT.

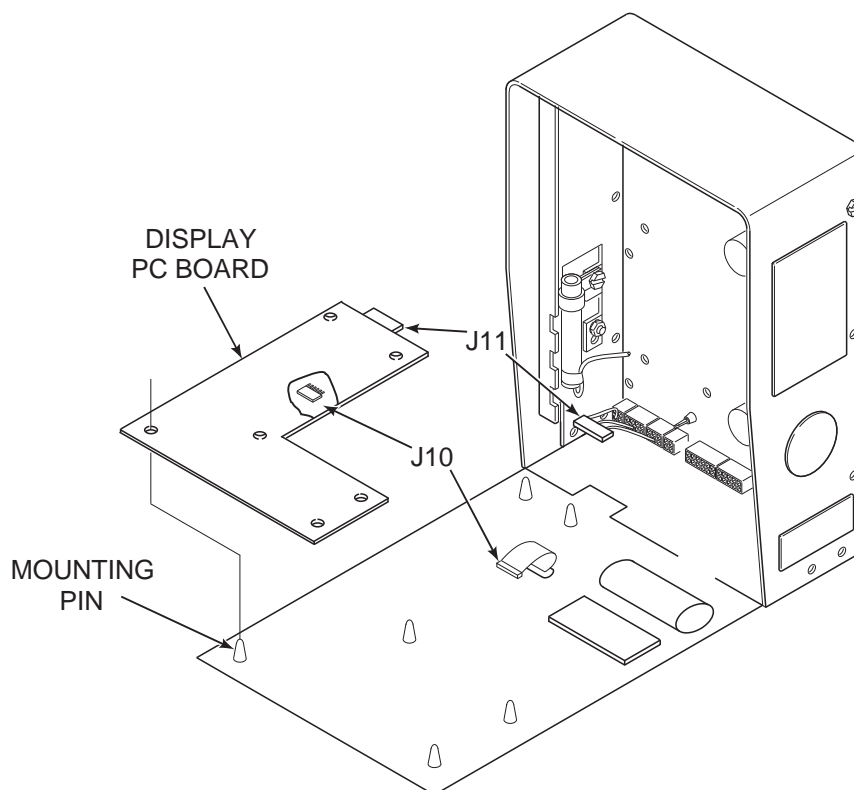
**REMOVAL PROCEDURE**

1. Remove input power to the DH-10 unit.
2. Using the 5/16 in. nutdriver, remove the two screws from the top of the control panel.
3. Lower the control panel.
4. Locate and remove plug J11 from the display board. Observe static electricity precautions. See Figure F.6.
5. Carefully pry the display board from the six mounting pins. Note that the keypad is still attached to the display board via plug J10.
6. Carefully remove plug J10 from the display board.

REPLACEMENT PROCEDURE

1. Install plug J10 into the new display board.
2. Mount the display board onto the six mounting pins.
3. Install plug J11 into the new display board.
4. Reinstall the control panel.

GAS SOLENOID REMOVAL AND REPLACEMENT

⚠ WARNING

Service and repair should only be performed by Lincoln Electric factory trained personnel. Unauthorized repairs performed on this equipment may result in danger to the technician or machine operator and will invalidate your factory warranty. For your safety and to avoid electrical shock, please observe all safety notes and precautions detailed throughout this manual.

If for any reason you do not understand the test procedures or are unable to perform the test/repairs safely, contact the Lincoln Electric service department for technical troubleshooting assistance before you proceed. Call 216-383-2531 or 1-800-833-9353(WELD).

DESCRIPTION

This procedure will aid the technician in the removal and replacement of either of the gas solenoids.

MATERIALS NEEDED

5/16 in. nutdriver
5/16 in. wrench
Pliers
Phillips head screwdriver

Return to Section TOC
Return to Master TOC

Return to Section TOC
Return to Master TOC

Return to Section TOC
Return to Master TOC

Return to Section TOC
Return to Master TOC

GAS SOLENOID REMOVAL AND REPLACEMENT *(continued)*

FIGURE F.7 — GAS SOLENOID REMOVAL AND REPLACEMENT.

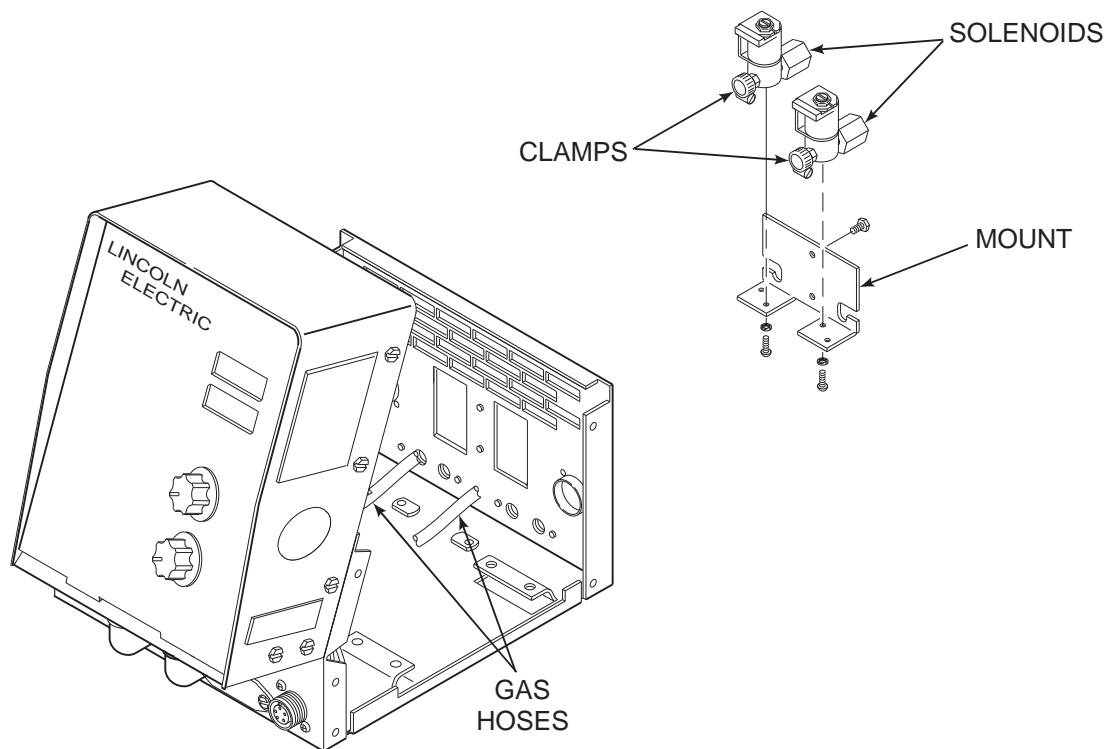

NOTE: WIRE FEEDER SHOWN WITH DRIVE MOTOR ASSEMBLY REMOVED FOR CLARITY

PROCEDURE

1. Remove input power to the DH-10 unit.
2. Using the 5/16 in. nutdriver, remove the wire drive cover.
3. Locate the gas solenoid assembly and remove the input gas lines. See Figure F.7.
4. Label and remove the four leads (two for each solenoid) connected to the solenoids.
5. Remove the two rubber hoses and clamps from the gas solenoids. Be careful not to damage the rubber hoses.
6. Using the 5/16 in. wrench remove the two screws that mount the solenoid assembly to the rear panel of the wire feeder.
7. Remove the solenoid assembly from the DH-10 unit.
8. Using the Phillips head screwdriver remove the two screws holding the solenoid to the bracket. Remove the solenoid.
9. Mount the new solenoid onto the bracket using the two Phillips head screws.
10. Install the solenoid assembly into the DH-10.
11. Connect the two gas hoses.
12. Connect the four wires previously removed. Be sure the leads are connected to the correct solenoid.
13. Install the wire drive cover and connect the input gas lines.

ENCODER PC BOARD REMOVAL AND REPLACEMENT

⚠ WARNING

Service and repair should only be performed by Lincoln Electric factory trained personnel. Unauthorized repairs performed on this equipment may result in danger to the technician or machine operator and will invalidate your factory warranty. For your safety and to avoid electrical shock, please observe all safety notes and precautions detailed throughout this manual.

If for any reason you do not understand the test procedures or are unable to perform the test/repairs safely, contact the Lincoln Electric service department for technical troubleshooting assistance before you proceed. Call 216-383-2531 or 1-800-833-9353(WELD).

DESCRIPTION

This procedure will aid the technician in the removal and replacement of either the WFS or Volts control encoder boards.

MATERIALS NEEDED

5/16 in. nutdriver
5/64 in. Allen wrench
1/2 in. wrench

Return to Section TOC
Return to Master TOCReturn to Section TOC
Return to Master TOCReturn to Section TOC
Return to Master TOCReturn to Section TOC
Return to Master TOC

ENCODER PC BOARD REMOVAL AND REPLACEMENT *(continued)*

FIGURE F.8 — ENCODER PC BOARD REMOVAL AND REPLACEMENT.

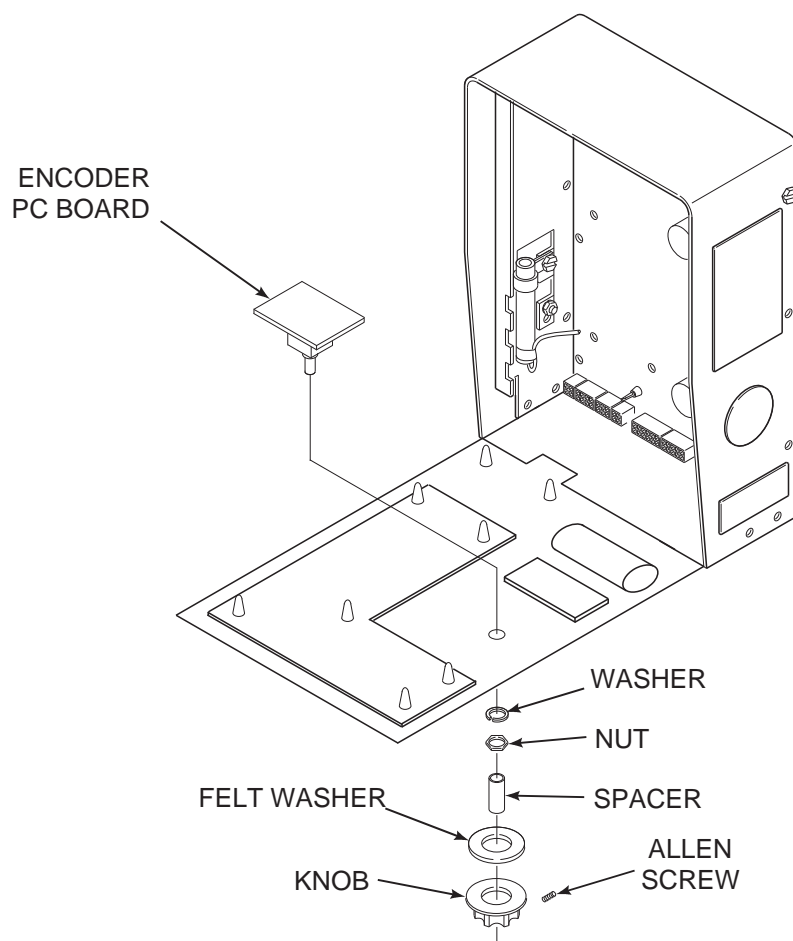
**PROCEDURE**

1. Remove input power to the DH-10 unit.
2. Using the 5/16 in. nutdriver remove the two screws from the top of the control panel.
3. Lower the control panel.
4. Using the 5/64 in. Allen wrench remove the control knob, spacer and felt washer from the encoder board that is to be removed. See Figure F.8.
5. Using the 1/2 in. wrench remove the nut and washer from the control shaft.
6. Carefully remove the PC board from the front panel.
7. Remove the harness plug from the encoder PC board.
8. Install the harness plug into the new encoder PC board.
9. Assemble the PC board into the front panel and secure with the washer and nut previously removed.
10. Assemble the felt washer, spacer and control knob onto the shaft and secure with the 5/64 in. Allen wrench.
11. Replace the control panel.

WIRE DRIVE MOTOR AND GEAR BOX REMOVAL AND REPLACEMENT**⚠ WARNING**

Service and repair should only be performed by Lincoln Electric factory trained personnel. Unauthorized repairs performed on this equipment may result in danger to the technician or machine operator and will invalidate your factory warranty. For your safety and to avoid electrical shock, please observe all safety notes and precautions detailed throughout this manual.

If for any reason you do not understand the test procedures or are unable to perform the test/repairs safely, contact the Lincoln Electric service department for technical troubleshooting assistance before you proceed. Call 216-383-2531 or 1-800-833-9353(WELD).

DESCRIPTION

The procedure will aid the technician in the removal and replacement of either the motor or gear box. These instructions are applicable for either the left or right side wire feed assemblies.

MATERIALS NEEDED

5/16 in. nutdriver
Pliers
3/16 in. Allen wrench
7/16 in. socket wrench and extension
3/4 in. wrench
5/16 in. wrench
Slot head screwdriver

DH-10

LINCOLN[®]
ELECTRIC

WIRE DRIVE MOTOR AND GEAR BOX REMOVAL AND REPLACEMENT *(continued)*

FIGURE F.9 — WIRE FEED ASSEMBLY REMOVAL.

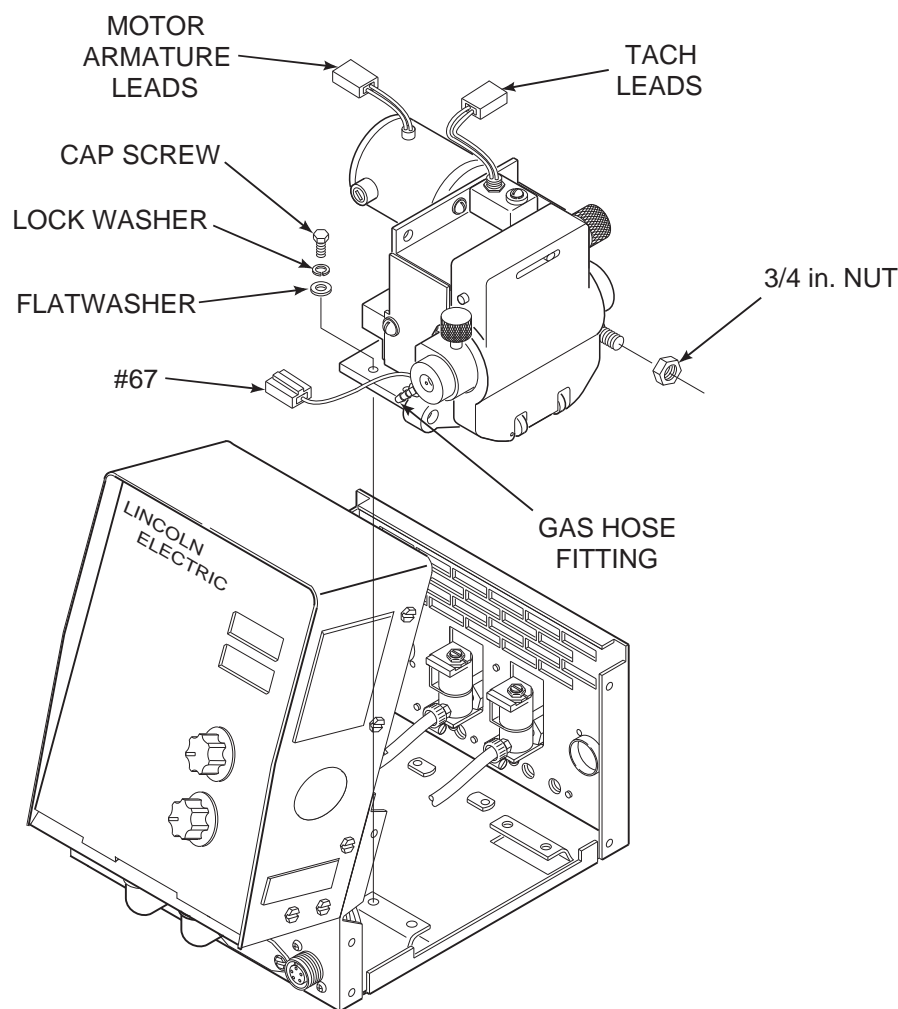
**PROCEDURE**

1. Remove input power to the DH-10 unit.
2. Remove the electrode wire from the wire drive.
3. Using the 5/16 in. nutdriver remove the wire drive cover.
4. Disconnect the #67 lead at the quick connect. See Figure F.9.
5. Disconnect the gas hose from the brass gun connector.
6. Disconnect the tach (hall effect device) leads.
7. Disconnect the motor armature leads.
8. Remove any necessary cable ties.
9. Using the 3/4 in. wrench remove the electrode cable from the wire feed assembly.
10. Using the 7/16 in. socket wrench and extension remove four mounting screws, lock washers and flat washers. The motor, gear box and feed head assembly are now free from the DH-10 unit.
11. Remove the wire feed assembly.

WIRE DRIVE MOTOR AND GEAR BOX REMOVAL AND REPLACEMENT *(continued)*

FIGURE F.10 — DRIVE MOTOR AND WIRE DRIVE ASSEMBLY REMOVAL.

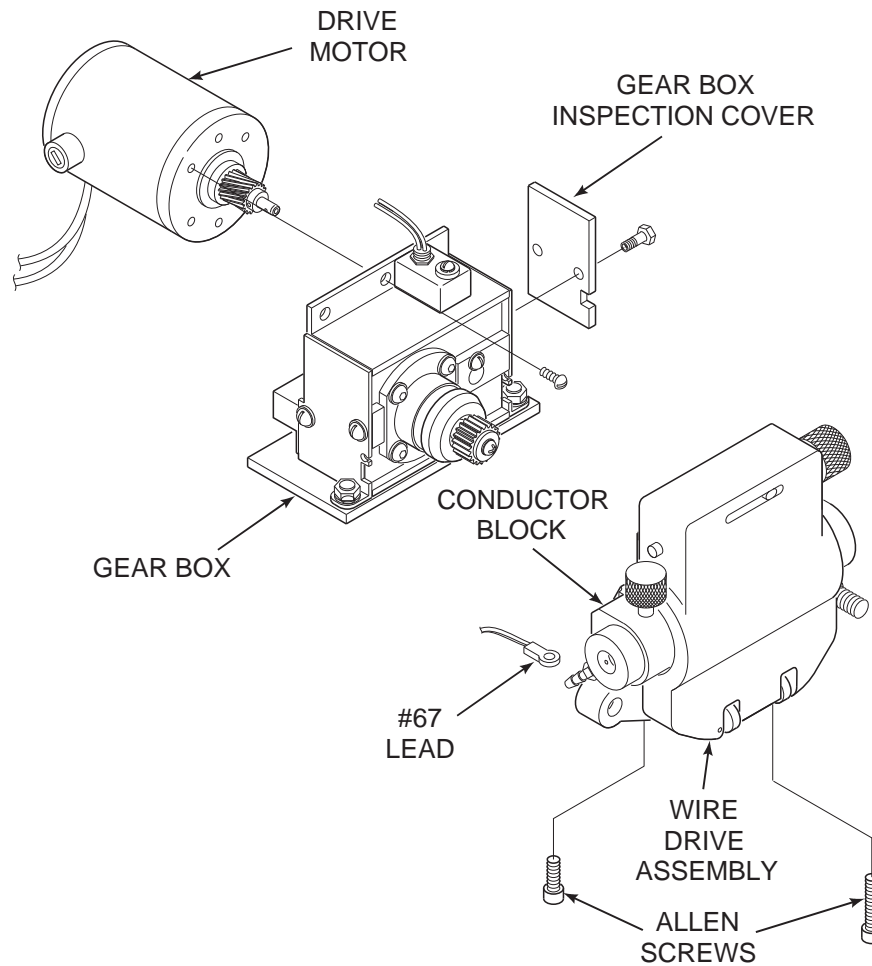
**TO REMOVE THE DRIVE MOTOR FROM THE GEAR BOX:**

12. Using the slot head screwdriver and 7/16 in. wrench remove the gear box inspection cover nearest to the drive motor. See Figure F.10.
13. Using the 5/16 in. wrench remove the motor mounting screw located inside the gear box.
14. Using the slot head screwdriver remove the two screws mounting the "top" of the motor to the gear box.
15. Carefully remove the drive motor from the gear box assembly. Note motor lead placement for reassembly.

TO REMOVE THE WIRE DRIVE ASSEMBLY FROM THE GEAR BOX:

16. Using the 3/16 in. Allen wrench loosen the two Allen screws located at the bottom of the wire drive unit.
17. Remove lead #67 from the conductor block.
18. Carefully slide and remove the wire drive assembly from the gear box assembly.

WIRE DRIVE MOTOR AND GEAR BOX REMOVAL AND REPLACEMENT *(continued)***REPLACEMENT PROCEDURES**

1. Carefully slide the wire drive assembly and gear box together.
2. Tighten the two Allen type screws at the bottom of the wire drive unit using the 3/16 in. Allen wrench.
3. Attach lead #67 to the conductor block.
4. Carefully slide the drive motor into the gear box assembly. Be sure to position the motor leads so that they can be properly connected.
5. Install the slot head screws that mount the "top" of the drive motor to the gear box.
6. Install the mounting screw located inside the gear box using the 5/16 in. wrench.
7. Install the gear box inspection cover and secure it with the slot head screws and nut previously removed.
8. Place the entire assembly into the DH-10 unit. Align the mounting holes with wire feeder base.
9. Secure the assembly to the wire feeder base using the four screws, lock washers and flat washers previously removed.
10. Connect the gas hose to the brass gun conductor block.
11. Connect the motor armature leads.
12. Connect the tach (hall effect device) leads.
13. Connect lead #67 quick connects together.
14. Connect the electrode cable to the to the wire feed assembly.
15. Replace any cut or removed cable ties.
16. Install the wire drive cover.

RETEST AFTER REPAIR

If a failed test indicates that any mechanical part which could affect the machine's electrical characteristics must be replaced, or if any electrical components are repaired or replaced, the machine must be retested and meet the following standards.

Apply the correct input power (42 VAC) to the DH-10 unit. The following checks should be performed for both wire drive units (left and right):

1. Press the Purge key. The gas solenoid should activate, then deactivate when the key is released.
2. Press the Cold Feed Forward key. Check that the direction of rotation of the drive roll is correct to feed wire out of the front of the machine. Check that the drive roll shaft stops abruptly when the key is released.
3. Press the Cold Feed Reverse key. Check that the direction of rotation of the drive roll is correct to retract the electrode wire back into the machine. Check that the drive roll shaft stops abruptly when the key is released.

Check the Feeder selection and Procedure keys for proper operation.

1. Press the Trigger key. The LEDs should toggle through the various trigger selections as the key is pressed and released.
2. Press the Timer key. The LEDs should toggle through the various modes as the key is pressed and released.
3. Press the Control key. The "Run-In Volts/WFS" LED should light up. Press the Control key again. The LED should turn off.

The Volts and WFS control must function and change the appropriate display.

CHECK WIRE FEED SPEED RANGE

DH-10 with low speed gear installed:
35-500 IPM

DH-10 with high speed gear installed:
50-750 IPM

Return to Section TOC
Return to Master TOC

Return to Section TOC
Return to Master TOC

Return to Section TOC
Return to Master TOC

Return to Section TOC
Return to Master TOC

Return to Section TOC

Return to Section TOC

Return to Section TOC

Return to Section TOC

Return to Master TOC

Return to Master TOC

Return to Master TOC

Return to Master TOC

TABLE OF CONTENTS
ELECTRICAL DIAGRAMS SECTION

Electrical Diagrams Section.....	Section G
Wiring Diagram (Control) (L10218).....	G-2
Wiring Diagram (Wire Drive) (M17871)	G-3
Control Board Schematic (Sheet 1) (G3040-1)	G-4
Control Board Schematic (Sheet 2) (G3040-2)	G-5
Display Board Schematic (L10138)	G-6
Encoder Board Schematic (S22066)	G-7
Control Board Layout (G3041-2)	G-8
Display Board Layout (L10139-1)	G-9
Encoder Board Layout (M17797-1)	G-10

Return to Master TOC

Return to Master TOC

Return to Master TOC

Return to Master TOC

Wiring Diagram (Control) (L10218)

WIRING DIAGRAM (DH-10 CONTROL)

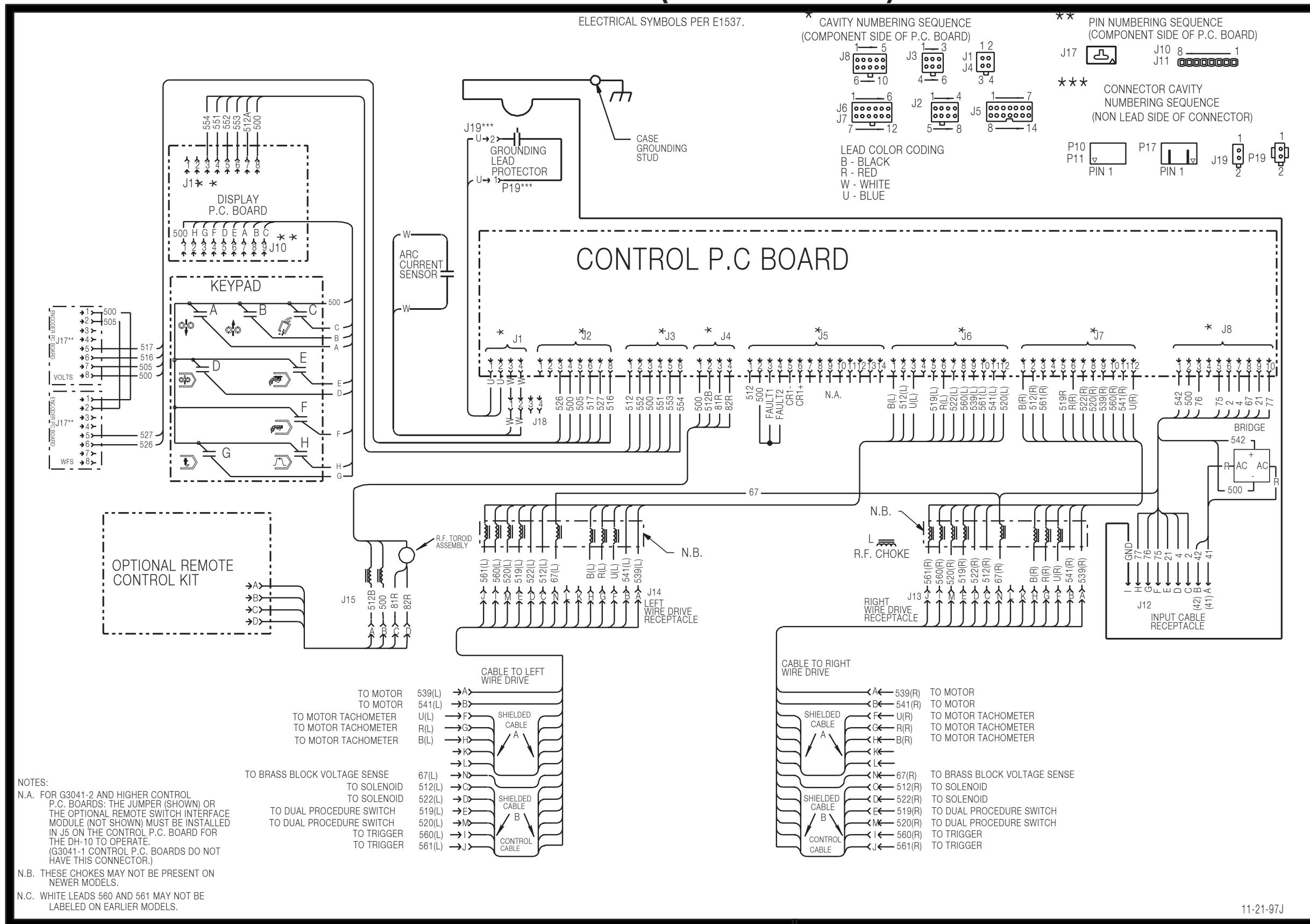

NOTE: This diagram is for reference only. It may not be accurate for all machines covered by this manual. The wiring diagram specific to your code is pasted inside one of the enclosure panels of your machine.

Return to Section TOC

Return to Master TOC

Return to Section TOC

Return to Master TOC

Return to Section TOC

Return to Master TOC

Return to Section TOC

Return to Master TOC

Control Board Schematic (Sheet 1) (G3040-1)

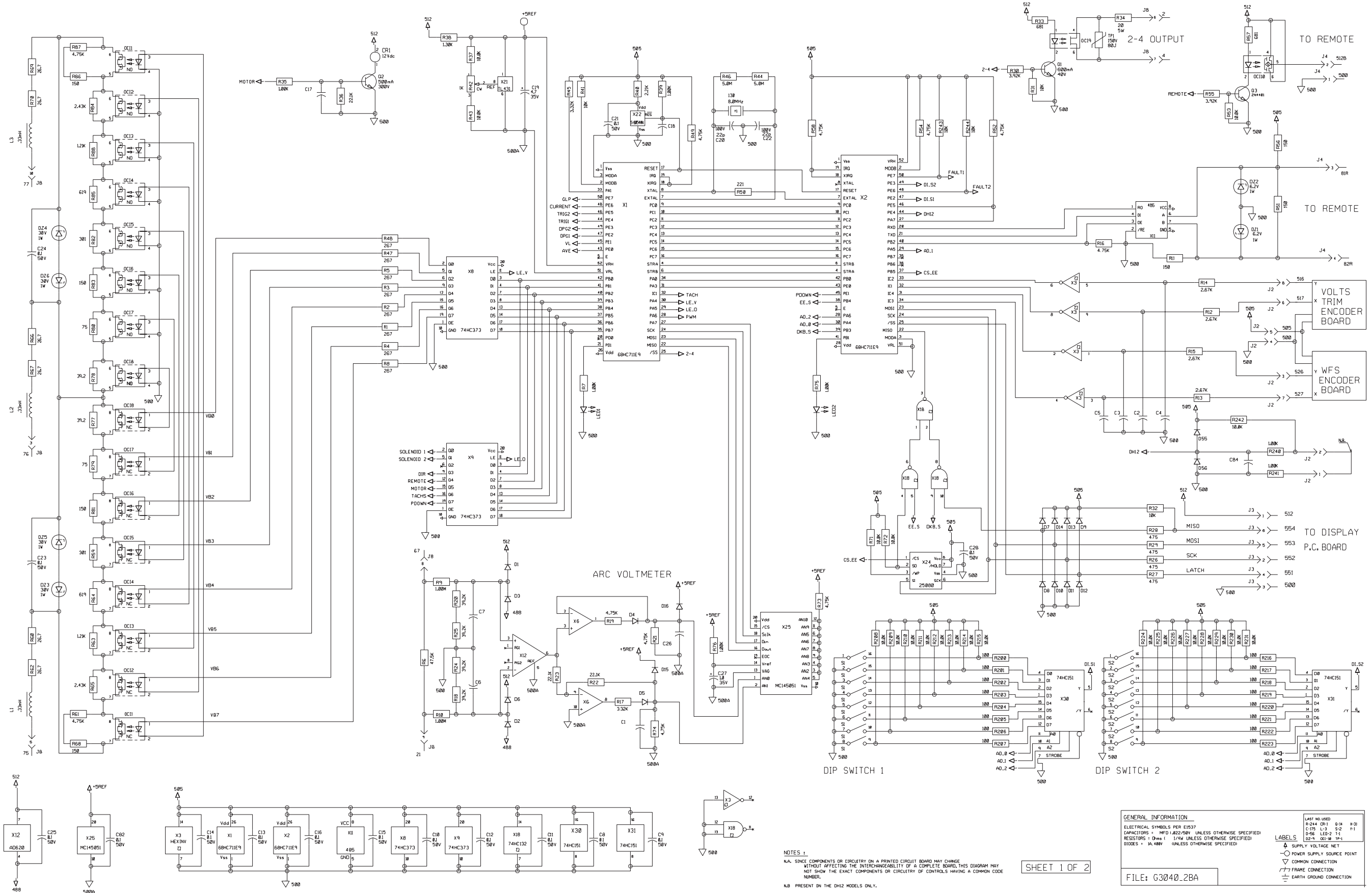

GENERAL INFORMATION

ELECTRICAL SYMBOLS PER EIA-197

CAPACITORS = MFD UNLESS OTHERWISE SPECIFIED

RESISTORS = OHMS (1/4W UNLESS OTHERWISE SPECIFIED)

DIODES = 1A 100V UNLESS OTHERWISE SPECIFIED

LAST NOT USED

R244 OR 1 0-14 4-31

C175 L-3 0-2 1-1

D96 LED-2 1-1

D2-1 001-08 1-1

LABELS

⊕ SUPPLY VOLTAGE NET

⊖ POWER SUPPLY SOURCE POINT

∇ COMMON CONNECTION

⌞ FRAME CONNECTION

⊥ EARTH GROUND CONNECTION

FILE: G3040.2BA

NOTES

1. N/A. SINCE COMPONENTS OR CIRCUITRY ON A PRINTED CIRCUIT BOARD MAY CHANGE WITHOUT AFFECTING THE INTERCHANGEABILITY OF A COMPLETE BOARD, THIS DIAGRAM MAY NOT SHOW THE EXACT COMPONENTS OR CIRCUITRY OF CONTROLS HAVING A COMMON CODE NUMBER.

2. B PRESENT ON THE DH2 MODELS ONLY.

SHEET 1 OF 2

5-2-97
G3040-1

NOTE: Lincoln Electric assumes no responsibility for liabilities resulting from board level troubleshooting. PC Board repairs will invalidate your factory warranty. **Individual Printed Circuit Board Components are not available from Lincoln Electric.** This information is provided for reference only. Lincoln Electric discourages board level troubleshooting and repair since it may compromise the quality of the design and may result in danger to the Machine Operator or Technician. Improper PC board repairs could result in damage to the machine.



G3040-1
5-2-97
DH-10

Return to Section TOC

Return to Master TOC

Control Board Schematic (Sheet 2) (G3040-2)

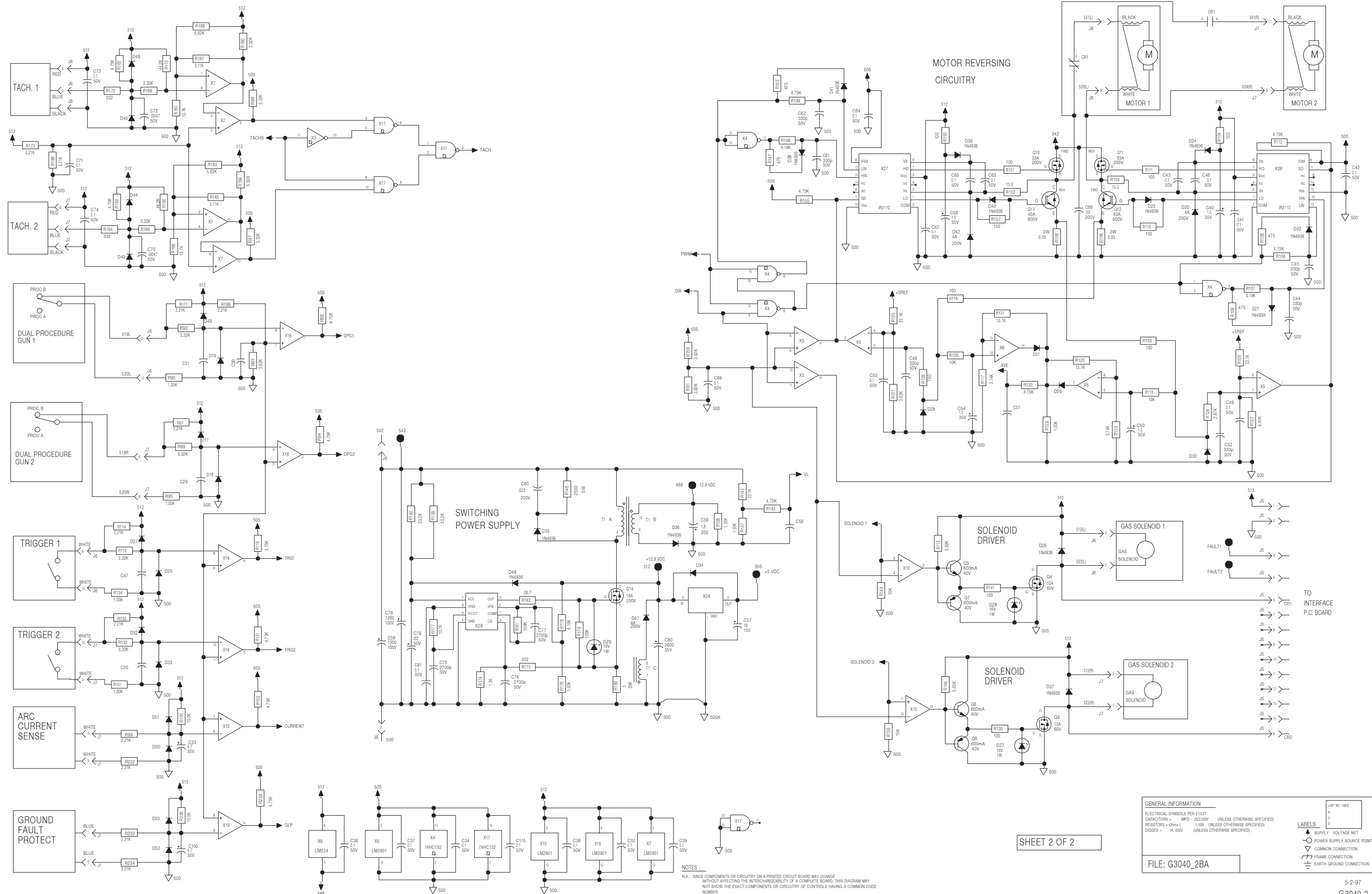

NOTE: Lincoln Electric assumes no responsibility for liabilities resulting from board level troubleshooting. PC Board repairs will invalidate your factory warranty. **Individual Printed Circuit Board Components are not available from Lincoln Electric.** This information is provided for reference only. Lincoln Electric discourages board level troubleshooting and repair since it may compromise the quality of the design and may result in danger to the Machine Operator or Technician. Improper PC board repairs could result in damage to the machine.



Return to Section TOC

Return to Master TOC

Return to Section TOC

Return to Master TOC

Return to Section TOC

Return to Master TOC

Return to Section TOC

Return to Master TOC

Return to Section TOC

Return to Master TOC

Return to Section TOC

Return to Master TOC

Return to Section TOC

Return to Master TOC

Return to Section TOC

Return to Master TOC

Return to Section TOC

Return to Master TOC

Return to Section TOC

Return to Master TOC

Return to Section TOC

Return to Master TOC

Return to Section TOC

Return to Master TOC

Return to Section TOC

Return to Master TOC

Return to Section TOC

Return to Master TOC

Return to Section TOC

Return to Master TOC

Return to Section TOC

Return to Master TOC

Return to Section TOC

Return to Master TOC

Return to Section TOC

Return to Master TOC

Return to Section TOC

Return to Master TOC

Return to Section TOC

Return to Master TOC

Return to Section TOC

Return to Master TOC

Return to Section TOC

Return to Master TOC

Return to Section TOC

Return to Master TOC

Return to Section TOC

Return to Master TOC

Return to Section TOC

Return to Master TOC

Display Board Schematic L10138)

Return to Section TOC

Return to Section TOC

Return to Section TOC

Return to Section TOC

NOTES:

1. N.A. SINCE COMPONENTS OR CIRCUITRY ON A PRINTED CIRCUIT BOARD MAY CHANGE, ELECTRICAL SYMBOLS PER EIB37 EFFECTIVE DATE MUST BE REFERENCED TO THE BOARD'S DISCRETE PARTS LIST TO SHOW THE EXACT COMPONENTS OR CIRCUITRY OR CONTROLS HAVING A COMMON CODE NUMBER.

GENERAL INFORMATION

ELECTRICAL SYMBOLS PER EIB37 UNLESS OTHERWISE SPECIFIED

CAPACITORS = MFD (102/100) UNLESS OTHERWISE SPECIFIED

RESISTORS = OHMS (1/4W) UNLESS OTHERWISE SPECIFIED

DIODES = 1A-400V UNLESS OTHERWISE SPECIFIED

FILENAME: L10138.LAB

5-2-97
L10138

LAST USED
R-31 LED 23
C-11
P-2

△ SUPPLY VOLTAGE POINT
○ COMMON CONNECTION
□ FRAME CONNECTION
⊥ EARTH GROUND CONNECTION

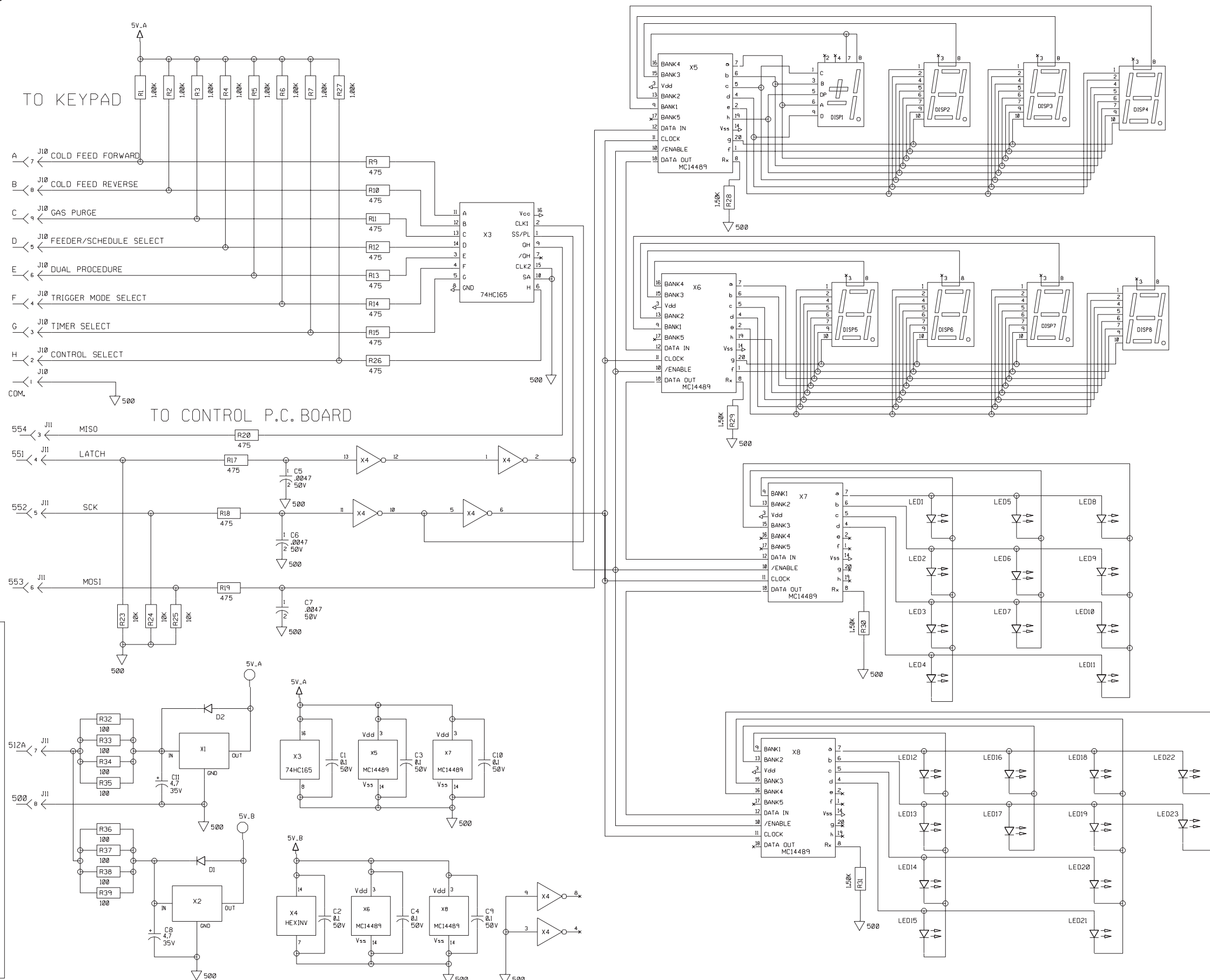

NOTE: Lincoln Electric assumes no responsibility for liabilities resulting from board level troubleshooting. PC Board repairs will invalidate your factory warranty. **Individual Printed Circuit Board Components are not available from Lincoln Electric.** This information is provided for reference only. Lincoln Electric discourages board level troubleshooting and repair since it may compromise the quality of the design and may result in danger to the Machine Operator or Technician. Improper PC board repairs could result in damage to the machine.



Encoder Board Schematic (S22066)

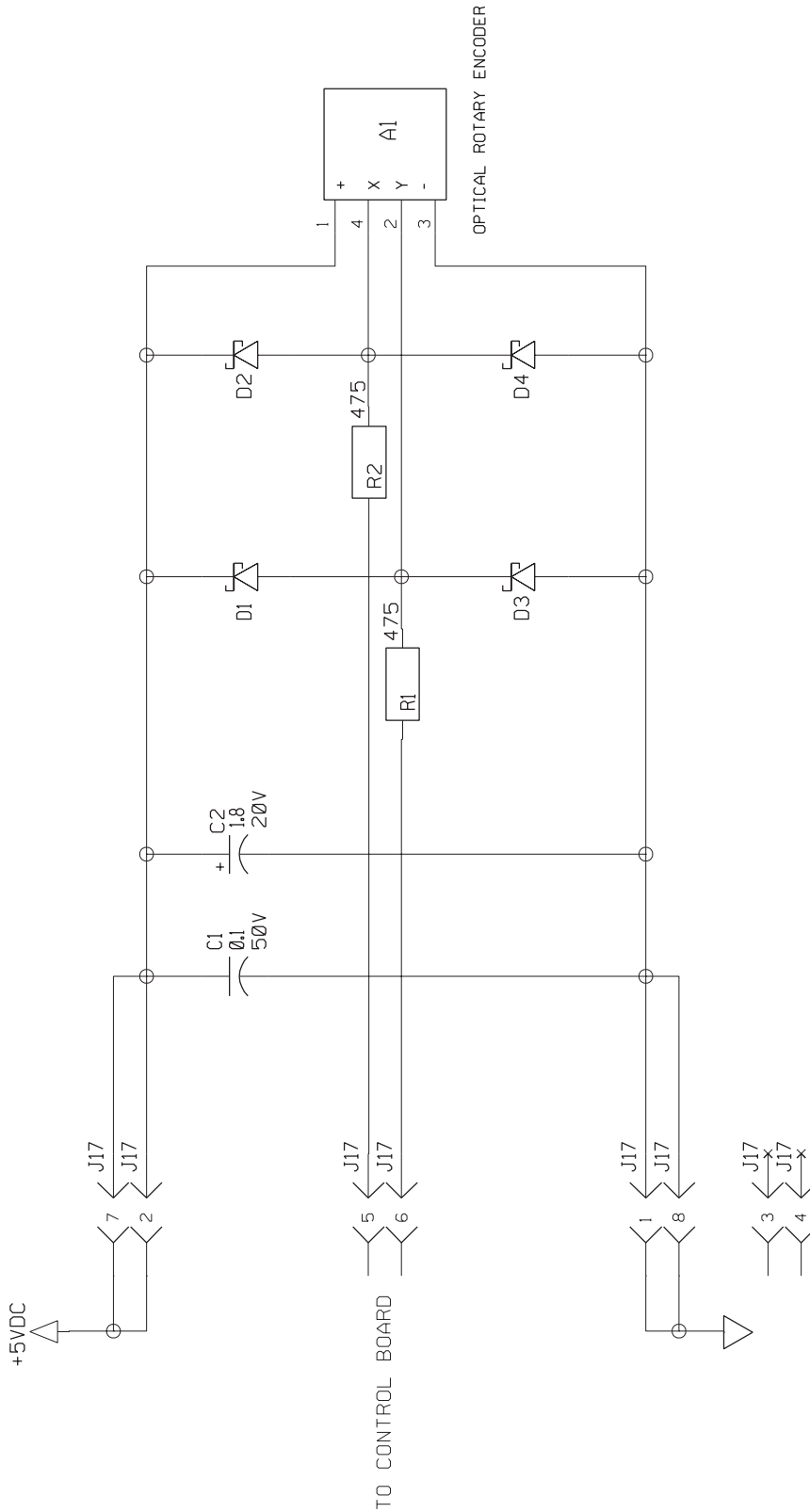

NOTES :

1.A. SINCE COMPONENTS OR CIRCUITRY ON A PRINTED CIRCUIT BOARD MAY CHANGE WITHOUT AFFECTING THE INTERCHANGEABILITY OF A COMPLETE BOARD, THIS DIAGRAM MAY NOT SHOW THE EXACT COMPONENTS OR CIRCUITRY OF CONTROLS HAVING A COMMON CODE NUMBER.

GENERAL INFORMATION

ELECTRICAL SYMBOLS PER E1537
 CAPACITORS = MFD (.022/50V UNLESS OTHERWISE SPECIFIED)
 RESISTORS = Ohms (1/4W UNLESS OTHERWISE SPECIFIED)
 DIODES = 1A, 400V (UNLESS OTHERWISE SPECIFIED)

LABELS

SUPPLY VOLTAGE NET
 POWER SUPPLY SOURCE POINT
 COMMON CONNECTION
 FRAME CONNECTION
 EARTH GROUND CONNECTION

4-7-95
S22066

NOTE: Lincoln Electric assumes no responsibility for liabilities resulting from board level troubleshooting. PC Board repairs will invalidate your factory warranty. **Individual Printed Circuit Board Components are not available from Lincoln Electric.** This information is provided for reference only. Lincoln Electric discourages board level troubleshooting and repair since it may compromise the quality of the design and may result in danger to the Machine Operator or Technician. Improper PC board repairs could result in damage to the machine.

DH-10



Control Board Layout (G3041-2)

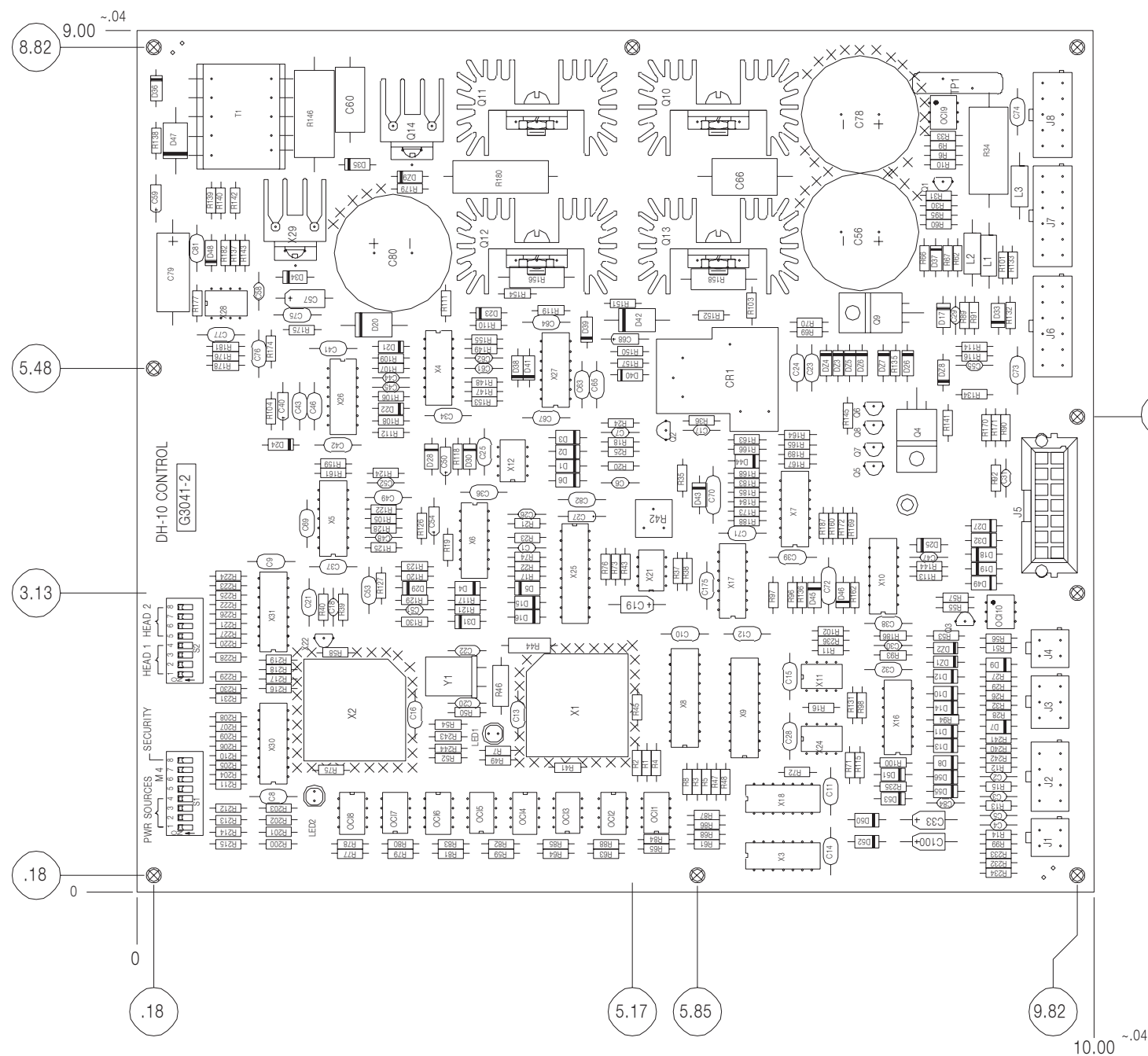

ITEM	REQ'D	PART NO.	DESCRIPTION
R17, R45, R89, R92, R96, R97, R116, R132, R160, R166, R169, R184	12	S19400-3321	3.32K 1/4W
R18, R20, R24, R25	4	S19400-3922	39.2K 1/4W
R22, R23, R36, R105, R125, R142	6	S19400-2212	22.1K 1/4W
R26, R27, R28, R29, R108, R109, R147, R153	8	S19400-4750	47.5 1/4W
R30, R55, R93, R127, R159, R161	6	S19400-3921	3.92K 1/4W
R31, R32, R37, R41, R43, R53, R71, R72, R100, R118, R126, R136, R144, R208, R209, R210, R211, R212, R213, R214, R215, R224, R225, R226, R227, R228, R229, R230, R231, R235, R242, R243, R244	33	S19400-1002	10K 1/4W
R33, R57	2	S19400-6810	681 1/4W
R34	1	T14648-23	20 ohm 5 watt
R38, R174	2	S19400-1301	1.3K 1/4W
R40, R91, R99, R114, R133, R171, R173, R186, R188, R232, R233, R234	12	S19400-2211	2.2K 1/4W
R42	1	T10812-68	1K 1/2W TRIMMER
R44, R46	2	T14230-23	5.0 MEG RESISTOR
R50	1	S19400-2210	22.1 1/4W
R59, R82	2	S19400-3010	30.1 1/4W
R60, R62, R66, R67, R69, R70	7	S19400-26R7	26.7 1/4W
R63, R88	2	S19400-1211	1.21K 1/4W
R64, R85	2	S19400-6190	61.9 1/4W
R65, R84	2	S19400-2431	2.43K 1/4W
R77, R78	2	S19400-39R2	39.2 1/4W
R79, R80	2	S19400-75R0	75 1/4W
R103, R104, R111, R119, R135, R141, R150, R151, R200, R201, R202, R203, R204, R205, R206, R207, R216, R217, R218, R219, R220, R221, R222, R223	24	S19400-1000	100 1/4W
R107, R149, R178	3	S19400-6191	6.19K 1/4W
R113, R145, R183, R189	4	S19400-5621	5.62K 1/4W
R117, R123	2	S19400-3741	3.74K 1/4W
R120, R121, R167, R168, R177	5	S19400-1372	13.7K 1/4W
R122	1	S19400-6811	6.81K 1/4W
R128	1	S19400-7500	750 1/4W
R137, R176	2	S19400-1501	1.5K 1/4W
R139, R140	2	S19400-3322	33.2K 1/4W
R146	1	T14648-9	5W / 2500 OHM RESISTOR
R152, R154	2	S19400-15R0	15 1/4W
R156, R158	2	T12300-66	.05/3W
R164, R170, R175	3	S19400-3320	33.2 1/4W
R165, R172	2	S19400-4422	44.2K 1/4W
R179	1	S19400-1003	100K 1/4W
R180	1	T12300-80	5 WATT 0.5 OHM RESISTOR
R181	1	S19400-1503	150K 1/4W
R185, R187	2	S19400-5111	5.11K 1/4W
S1, S2	2	S19869-8	SPST SLIDE SWITCH PACKAGE
T1	1	S20375-1	TRANSFORMER
TP1	1	T13640-16	80J
X1	1	S23091-4	I.C., CMOS, MCU (SS)
X2	1	S23092-5	I.C., CMOS, MCU (SS)
X3	1	S17900-8	14 PIN I.C. (SS)
X4, X17, X18	3	S17900-24	QUAD 2-INP/TT SCHMITT TRIG. NAND (SS)
X5, X7, X10, X16	4	S15128-11	14 PIN QUAD COMPARATOR
X6	1	S15128-4	LM224 OP-AMP
X8, X9	2	S17900-5	TRI-STATE OCTAL LATCH (SS)
X11	1	S20353-4	I.C. CMOS, XCVR, E1A485 (SS)
X12	1	S15128-20	AMPLIFIER
X21	1	S15128-10	VOLTAGE REF.
X22	1	M15102-3	RESET I.C. UNDERVOLT. SENSING CIR. (SS)
X24	1	M15104-8	I.C. EEPROM, SPI
X25	1	M15105-7	I.C. CMOS, MPU, A/D, 10-BIT
X26, X27	2	S15018-16	HV. GATE DRIVE (SS)
X28	1	M15458-4	8 PIN IC
X29	1	S18395-3	HEAT SINK ASBLY
X30, X31	2	S17900-26	SELECT/MULTIPLX (SS)
Y1	1	S16665-5	8.0 MHZ

ITEM	REQ'D	PART NO.	DESCRIPTION
C1, C2, C3, C4, C5, C6, C7, C17, C18, C26, C29, C30, C31, C47, C51, C55, C58, C84	18	S16668-5	.022/50
C8, C9, C10, C11, C12, C13, C14, C15, C16, C21, C23, C24, C25, C28, C32, C34, C36, C37, C38, C39, C41, C42, C43, C46, C49, C53, C63, C64, C65, C67, C69, C71, C73, C74, C81, C82, C175	37	S16668-11	.1/50
C19, C33, C100	3	S13490-25	4.7/35
C20, C22	2	S16668-1	220P/100
C27, C40, C50, C54, C68	5	S13490-42	1.0/35
C44, C45, C48, C52, C61, C62	6	S16668-8	330P/100
C56, C78	2	S13490-138	1200/100
C57	1	S13490-39	18/15
C59	1	S13490-19	1.8/20
C60	1	S13490-4	.022/200
C66	1	S13490-94	.33/200
C70, C72	2	S16668-10	4700P/50
C75, C76, C77	3	S16668-4	2700P/50
C79	1	S13490-73	20/50
C80	1	S13490-107	5600/35V
CR1	1	S15122-7	D.C. RELAY
D1, D2, D3, D4, D5, D6, D7, D8, D9, D10, D11, D12, D13, D14, D15, D16, D17, D18, D19, D25, D27, D28, D29, D30, D31, D32, D33, D34, D43, D44, D45, D46, D49, D50, D51, D52, D53, D55, D56, D20, D42, D47	39	T12199-1	IN4004
D21, D22, D23, D24, D26, D35, D36, D37, D38, D39, D40, D41, D48	13	T12705-34	IN4936
D71, D72	2	T12702-40	IN4735
D73, D74, D75, D76	4	T12702-38	IN4751
D77, D78, D79	3	T12702-11	IN4745A
J1, J4	2	S18248-4	HEADER
J2	1	S18248-8	CONNECTOR
J3	1	S18248-6	HEADER
J5	1	S21134-14	HEADER
J6, J7	2	S18248-12	HEADER
J8	1	S18248-10	HEADER
L1, L2, L3	3	T12218-7	330uH
LED1	1	T13657-2	RED LED
LED2	1	T13657-3	GREEN LED
OCI1, OCI2, OCI3, OCI4, OCI5	8	S15000-25	SOLID STATE RELAY
OCI6, OCI7, OCI8	2	S15000-20	PHOTO FET
OCI9, OCI10	2	S15000-25	PHOTO FET
Q1, Q3, Q5, Q8	4	T12704-68	2N4401
Q2	1	T12704-35	NPN TRANSISTOR
Q4, Q9	2	T12704-54	N-CHANNEL FET (SS)
Q6, Q7	2	T12704-69	2N4403
Q10, Q11	2	S20106-1	HEXFET W/ H. S. ASBLY (SS)
Q12, Q13	2	S20106-3	TRANSISTOR, I.G.D. T247, 600V
Q14	1	S18395-5	H. S. ASBLY (SS)
R1, R2, R3, R4, R5, R8, R47, R48, R6	8	S19400-2670	267 1/4W
R7, R35, R39, R75, R76, R90, R95, R101, R129, R134, R138, R240, R241	13	S19400-4752	47.5K 1/4W
R9, R10	2	S19400-1004	1M 1/4W
R11, R51, R56, R68, R81, R83, R86, R110, R157	9	S19400-1500	150 1/4W
R12, R13, R14, R15, R124	5	S19400-2671	2.67K 1/4W
R16, R19, R21, R49, R52, R54, R58, R61, R73, R74, R87, R94, R96, R102, R106, R112, R115, R130, R131, R143, R149, R155, R162, R163, R236	25	S19400-4751	4.75K

CAPACITORS = MFD/VOLTS
 RESISTORS = OHMS, 1/4 WATT UNLESS OTHERWISE SPECIFIED.
 INDUCTANCE = HENRYS

G 3041-2

Return to Section TOC

NOTE: Lincoln Electric assumes no responsibility for liabilities resulting from board level troubleshooting. PC Board repairs will invalidate your factory warranty. **Individual Printed Circuit Board Components are not available from Lincoln Electric.** This information is provided for reference only. Lincoln Electric discourages board level troubleshooting and repair since it may compromise the quality of the design and may result in danger to the Machine Operator or Technician. Improper PC board repairs could result in damage to the machine.



Display Board Layout (L10139-1)

Return to Section TOC

Return to Section TOC

Return to Section TOC

Return to Section TOC

Return to Master TOC

Return to Master TOC

Return to Master TOC

Return to Master TOC

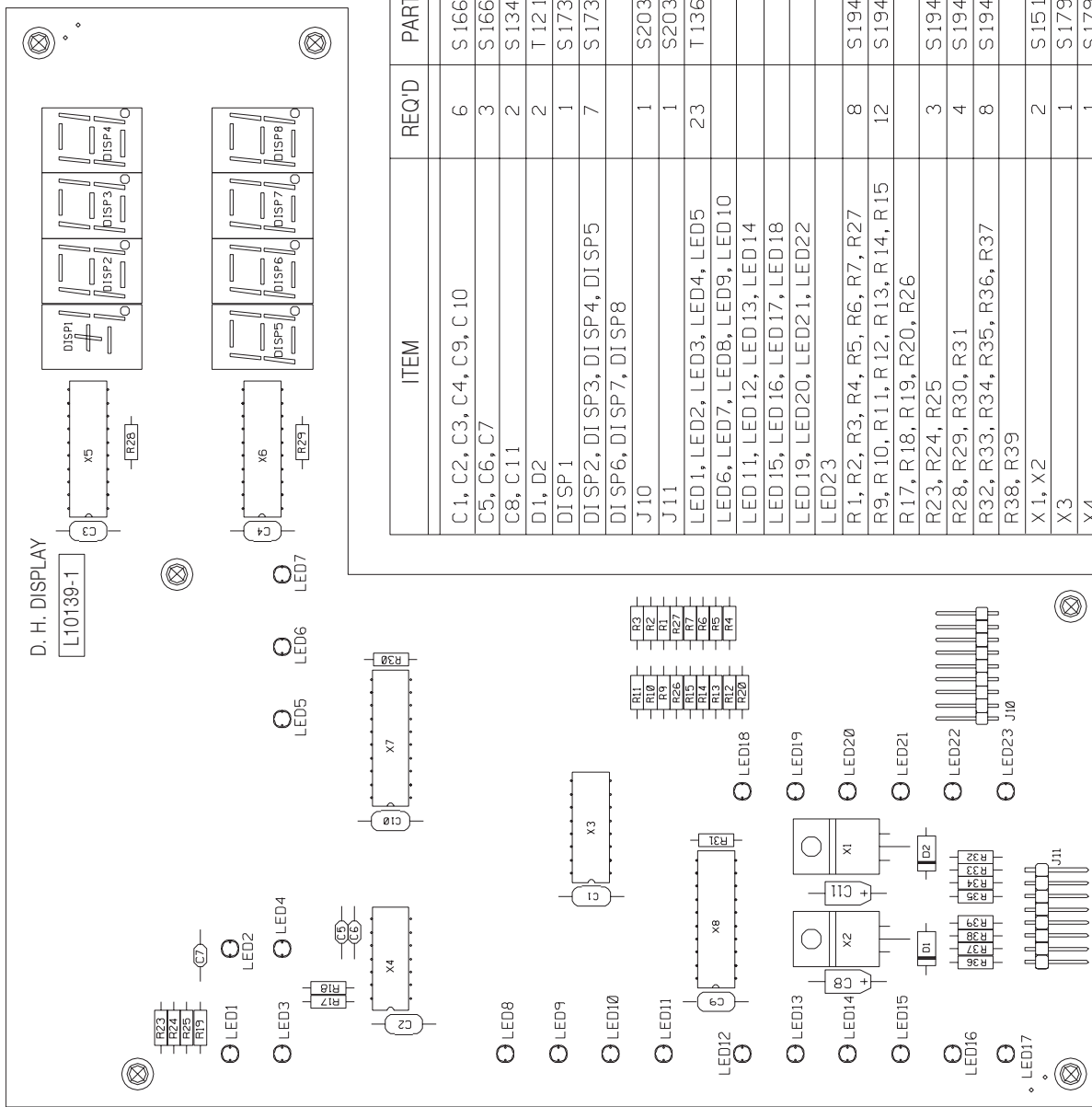

5-2-97
L10139-1

DH-10



NOTE: Lincoln Electric assumes no responsibility for liabilities resulting from board level troubleshooting. PC Board repairs will invalidate your factory warranty. **Individual Printed Circuit Board Components are not available from Lincoln Electric.** This information is provided for reference only. Lincoln Electric discourages board level troubleshooting and repair since it may compromise the quality of the design and may result in danger to the Machine Operator or Technician. Improper PC board repairs could result in damage to the machine.

Encoder Board Layout (M17797-1)

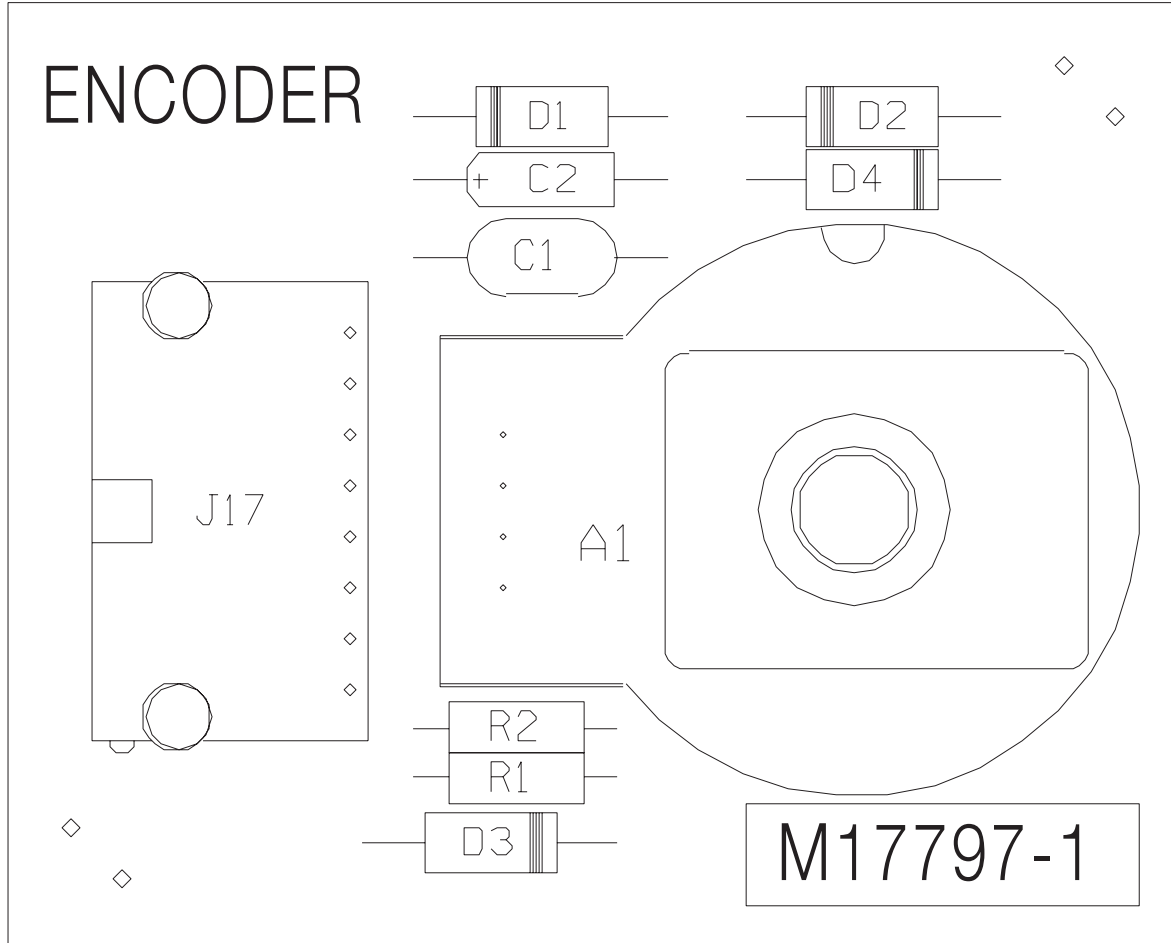

ITEM	REQ'D	PART NO	DESCRIPTION
C1	1	S1 6668-11	. 1 /50
C2	1	S1 3490-1 9	1 . 8/20
D1 , D2, D3, D4	4	T1 2705-23	1 N581 8
J1 7	1	S1 9365-8	RIGHT ANGLE HEADER
R1 , R2	2	S1 9400-4750	475 1 /4W

4-7-95
M17797-1

NOTE: Lincoln Electric assumes no responsibility for liabilities resulting from board level troubleshooting. PC Board repairs will invalidate your factory warranty. **Individual Printed Circuit Board Components are not available from Lincoln Electric.** This information is provided for reference only. Lincoln Electric discourages board level troubleshooting and repair since it may compromise the quality of the design and may result in danger to the Machine Operator or Technician. Improper PC board repairs could result in damage to the machine.

DH-10



M17797-1
4-7-95

Return to Section TOC

Return to Section TOC

Return to Section TOC

Return to Section TOC

Return to Master TOC

Return to Master TOC

Return to Master TOC

Return to Master TOC

NOTES

Return to Section TOC

Return to Section TOC

Return to Section TOC

Return to Section TOC

Return to Master TOC

Return to Master TOC

Return to Master TOC

Return to Master TOC

DH-10

